

# XX 1.2 GI 12 VX

The lens arrays of Fresnel Technologies' XX 1.2 GI 12 VX series are intended to be used in passive infrared motion detector devices. They are optimized for dual-element pyroelectric detectors. They are normally used with the grooved side facing the pyroelectric detector, and curved at a 1.2 inch (30.5 mm) radius about the sensitive area of the detector (see Figure 1). In this case, the detector and the lens array should be inclined downward at an angle of 12 degrees, for most of the types. The detector position should be 0.810" (20.6 mm) below the upper edge, and centered left-right (see Figure 2).

The overall dimensions of the arrays are 1.677"  $\pm$  0.010" (42.6 mm  $\pm$  0.3 mm) high by 2.402"  $\pm$  0.010" (61 mm  $\pm$  0.3 mm) wide by 0.015"  $\pm$  0.004" (0.38 mm  $\pm$  0.1 mm) thick. Border width is approximately 1/8" (3 mm). Centering is held to 0.015" (0.38 mm) in both directions.

Fresnel Technologies, Inc. is the premier manufacturer of Fresnel lens arrays. We have led the industry in the development of new lenses and materials to advance the state of the art of passive infrared motion detection. Our lenses and lens arrays have been incorporated into most passive infrared devices using refractive optics since 1976. Our quality standards are the highest in the industry. Surface finish and inclusions are such that no defect is visible at a distance of 3 feet (1 meter) under ordinary light. There are no functional flaws in our products whatsoever. Our POLY IR® infrared-transmitting materials are the best available in stiffness and in transmittance in the 8 to 14  $\mu$ m region. Active lens segments are made from our acclaimed and proprietary LODIFF® lens patterns. Patents have been issued or are pending on each of the designs in the XX 1.2 GI 12 VX series.

The members of the series are as follows:

#### **WIDE ANGLE ARRAYS**

WA 1.2 GI 12 V1  
WA 1.2 GI 12 V2  
WA 1.2 GI 12 V3  
WA 1.2 GI 12 V4  
WA 1.2 GI 12 V5

#### **EXTRA WIDE ANGLE ARRAYS**

EWA 1.2 GI 12 V1  
EWA 1.2 GI 12 V2  
EWA 1.2 GI 12 V3

#### **DENSE WIDE ANGLE ARRAYS**

DWA 1.2 GI 12 V1  
DWA 1.2 GI 12 V2

#### **LONG RANGE ARRAYS**

LR 1.2 GI 12 V1  
LR 1.2 GI 12 V2  
LR 1.2 GI 12 V3

#### **PET IMMUNE ARRAYS**

WP 1.2 GI 12 V1  
EWP 1.2 GI V1

#### **ANIMAL ALLEY ARRAYS**

AA 1.2 GI 12 V1  
AA 1.2 GI V1  
AA 1.2 GI V2  
AA 1.2 GI V3

#### **VERTICAL BARRIER ARRAYS**

VB 1.2 GI V1  
VB 1.2 GI V2  
VB 1.2 GI 12 V1

Figures 3-30 illustrate the zone patterns for the arrays. The figures postulate a dual-element detector with 110° coverage both up-down and left-right, amplifier gain of about 5,000, and a mounting height of 3.3 feet (1 meter) for the animal alley lens arrays and 6.8 feet (2.1 meters) for the others, and the 12° tilt for all arrays except the animal alley lens arrays. The AA 1.2 GI 12 V1 is designed to be used at a height of 3.3 feet (1 meter) from the floor, in a unit which retains the 12° downward tilt. The AA 1.2 GI V1 and the AA 1.2 GI V2 are designed to be used at a height of 3.3 feet (1 meter) from the floor, in a unit which is not inclined when mounted at this height but which is inclined downward 12° when mounted at the normal height of 6.8 feet (2.1 meters). The AA 1.2 GI V3 is designed to be used at a height of 3.3 feet (1 meter) from the floor in a unit which is not inclined downward at any mounting height. The VB 1.2 GI V2 is shown in a configuration useful for personnel detection near a door, with the detector mounted so it looks down at the floor.

If you wish to use arrays from the XX 1.2 GI 12 VX series at a tilt angle other than 12°, you should move the detector up 0.021" (0.53 mm) for each degree less than 12°, or down by the same amount for each degree greater than 12°. The animal alley lens arrays discussed above are designed to be used at the angles specified, so that this movement is unnecessary.

Other configurations (smooth side toward the detector, curved at other radii, tilted at other angles, etc.) can be used as well, but the zone patterns illustrated in Figures 3-21 will not apply. As examples, we offer Figures 24-29, some of which illustrate various XX 1.2 GI 12 VX series arrays curved at a 1.2" radius but not tilted downward 12°, and others of which show them held flat. Other examples are available on request.

**fresnel**  
**technologies inc.**

101 WEST MORNINGSIDE DRIVE  
FORT WORTH, TEXAS 76110  
(817) 926-7474  
FAX: (817) 926-7146  
[www.fresneltech.com](http://www.fresneltech.com)

**TOP VIEW:**

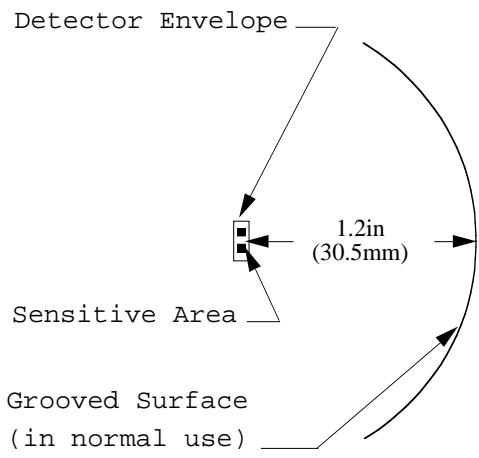

**FRONT VIEW:**

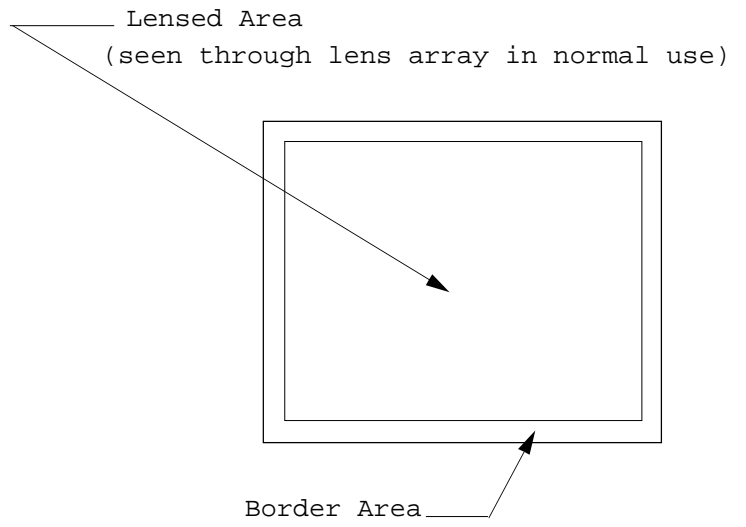

**FIGURE 1**

**SIDE VIEW:**

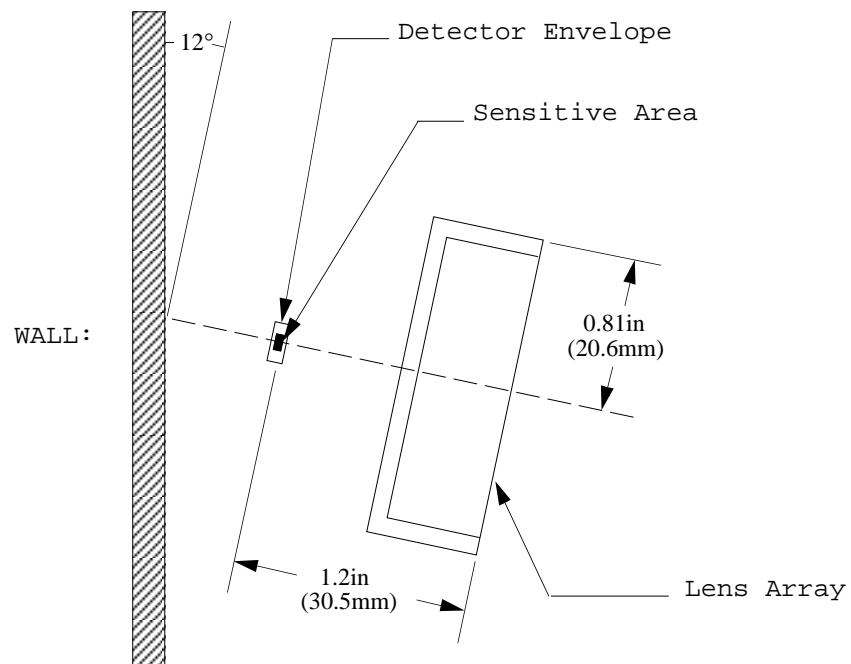
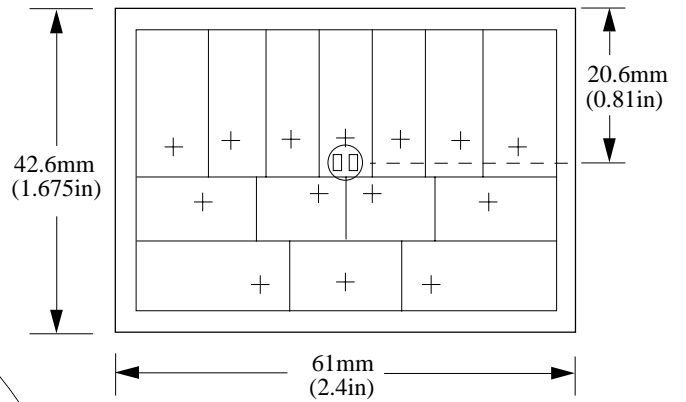

**FIGURE 2**

# WIDE ANGLE ARRAY

WA 1.2 GI 12 V1

## FRONT VIEW:



## TOP VIEW:

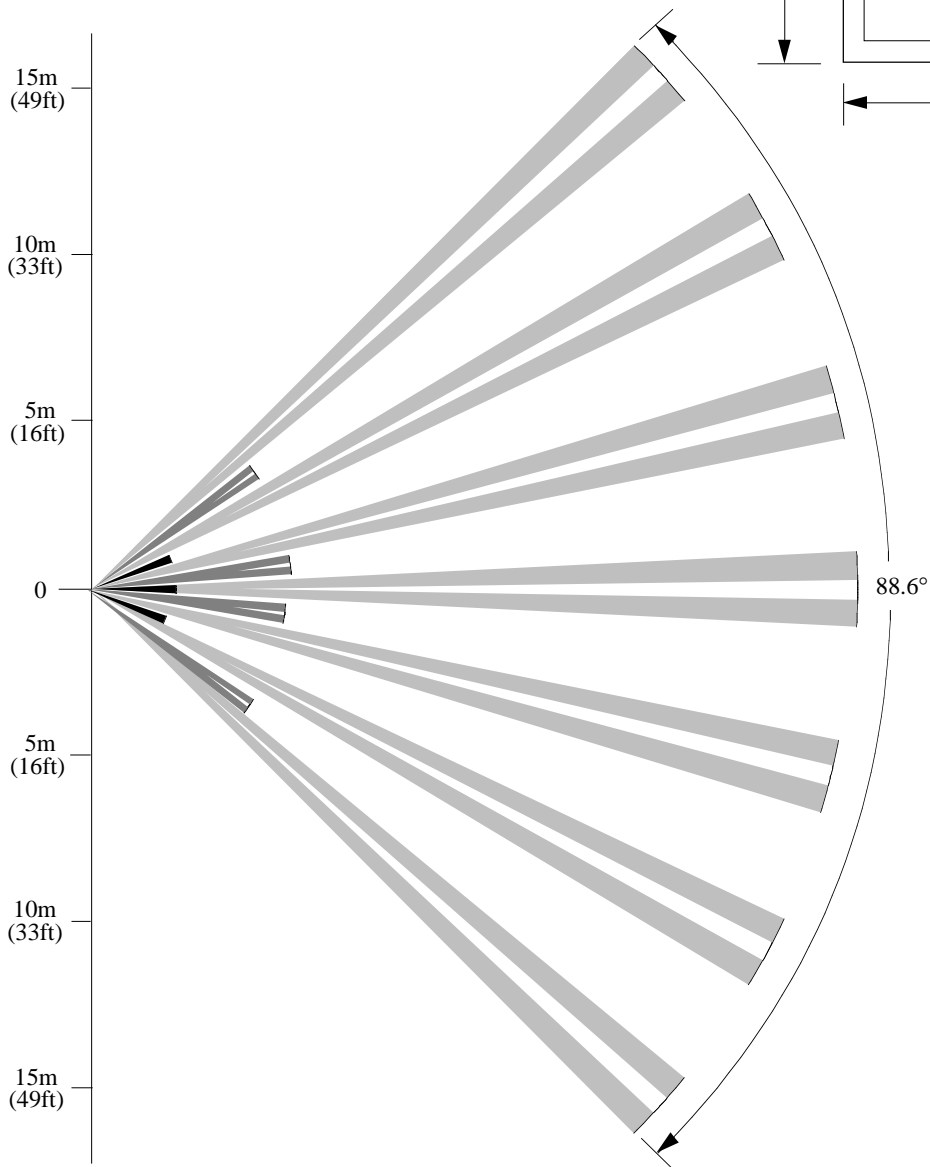

## SIDE VIEW:

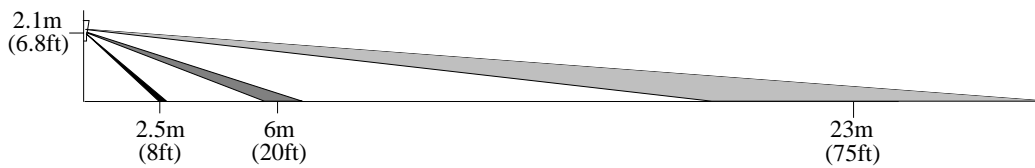
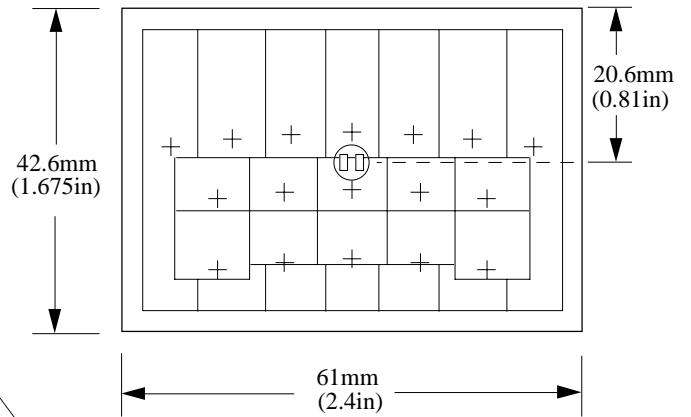

Figure 3

# WIDE ANGLE ARRAY

WA 1.2 GI 12 V2

## FRONT VIEW:



## TOP VIEW:

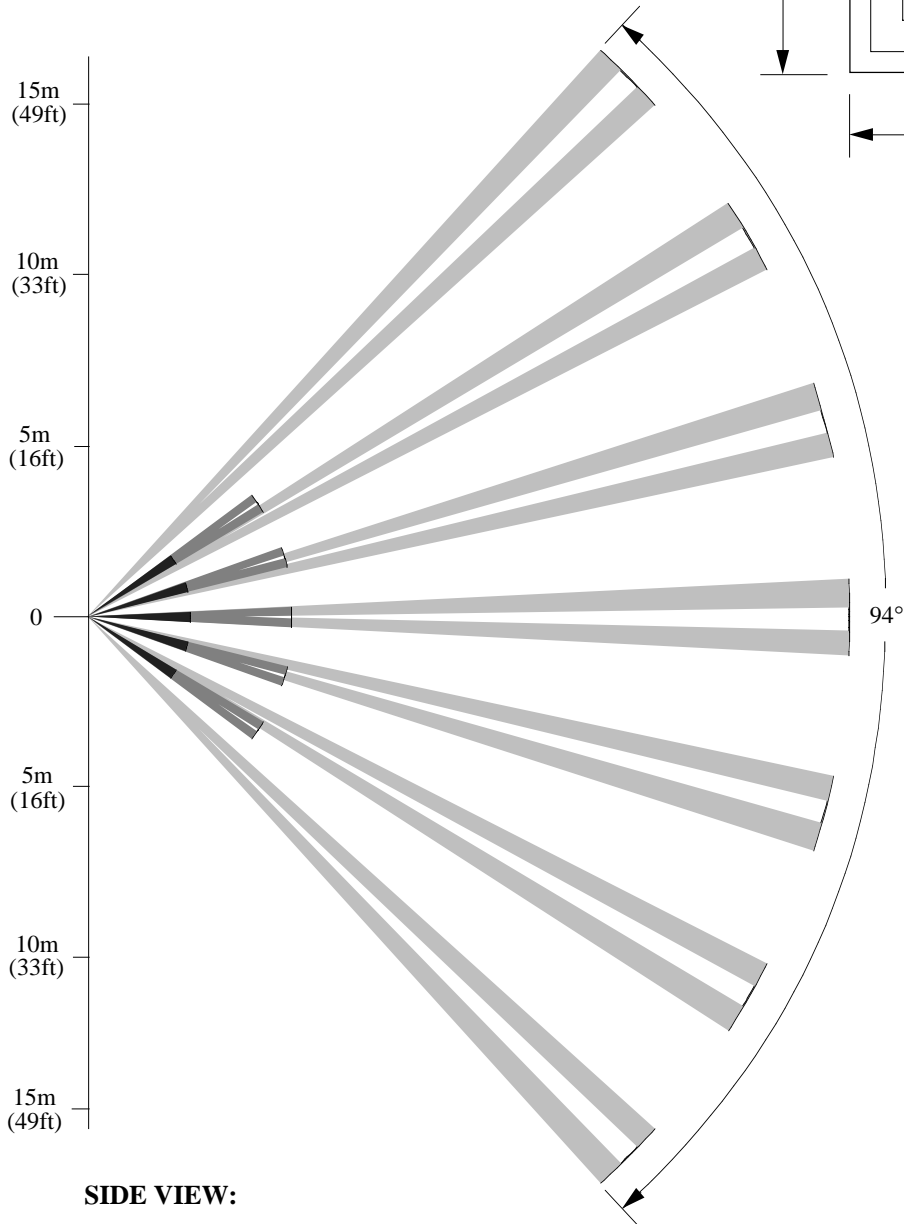

## SIDE VIEW:

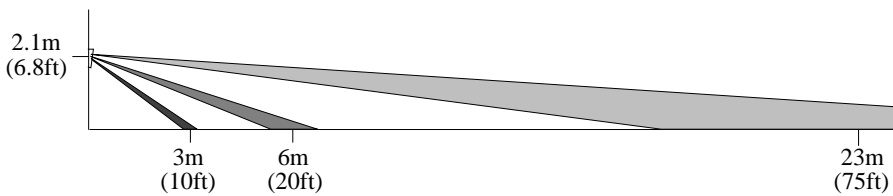
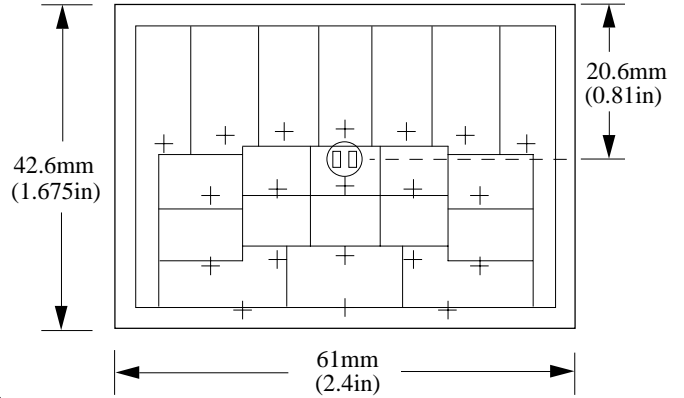

Figure 4

# WIDE ANGLE ARRAY

WA 1.2 GI 12 V3

## FRONT VIEW:



## TOP VIEW:

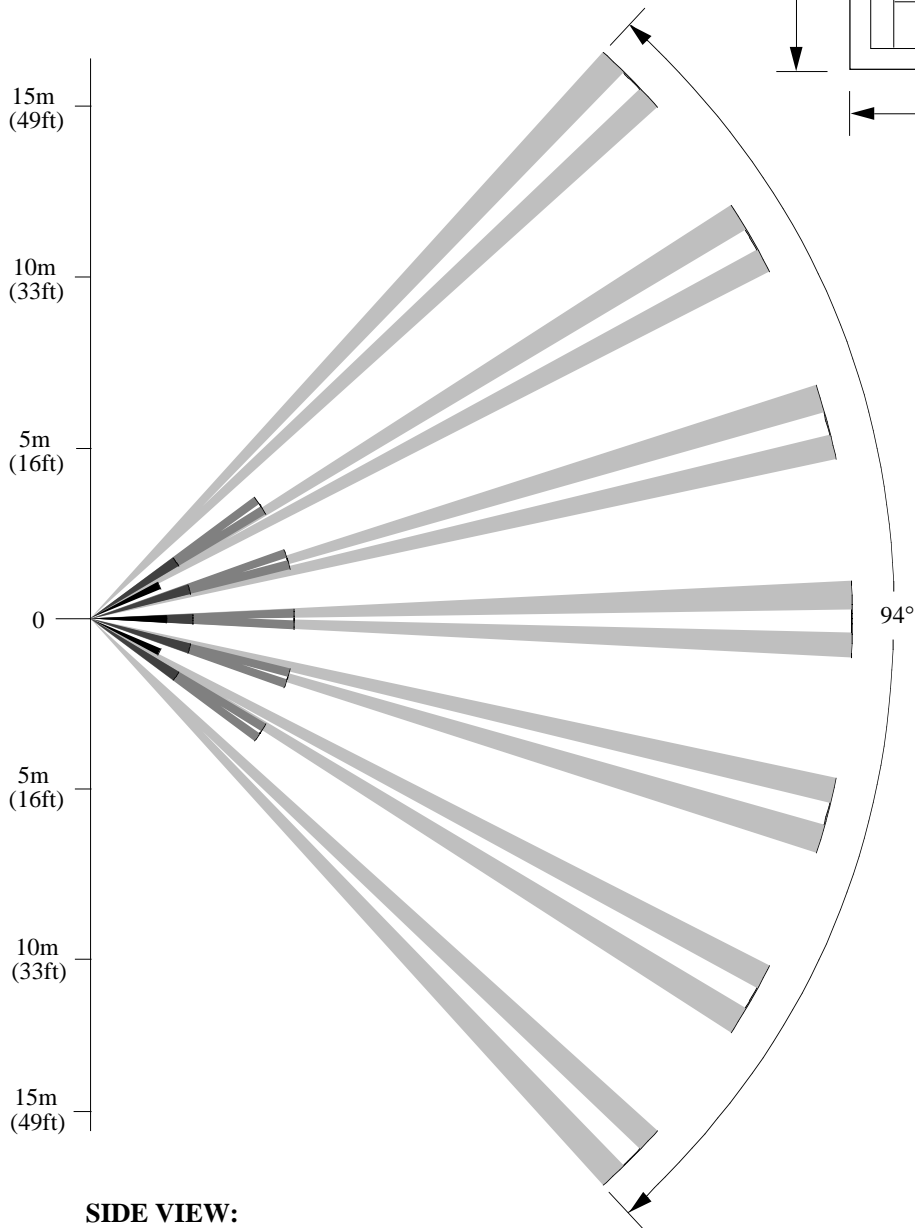

## SIDE VIEW:

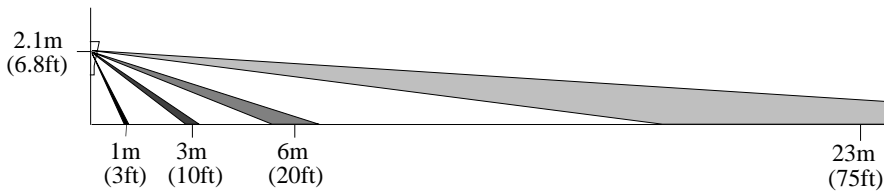

Figure 5

# WIDE ANGLE ARRAY

WA 1.2 GI 12 V4

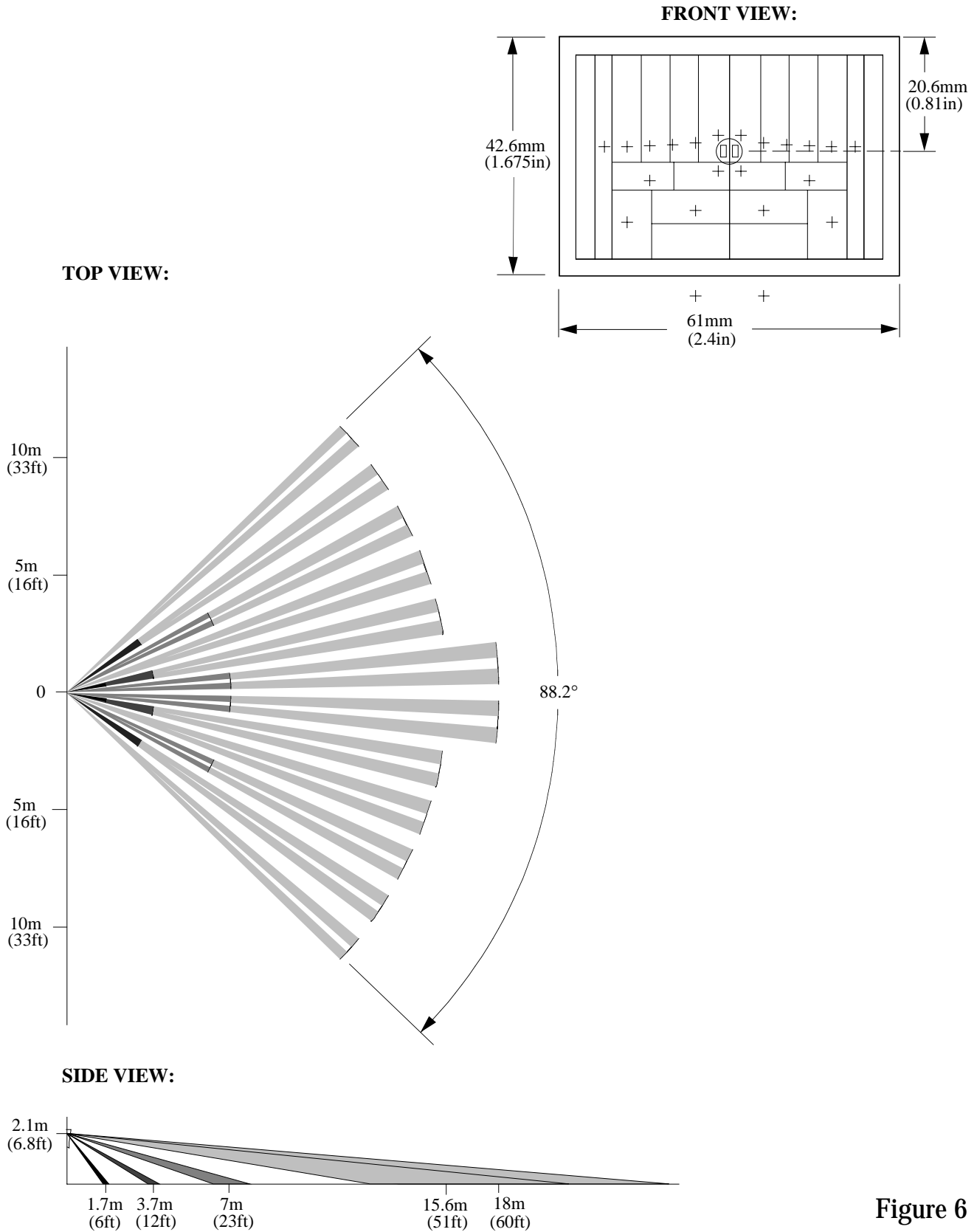
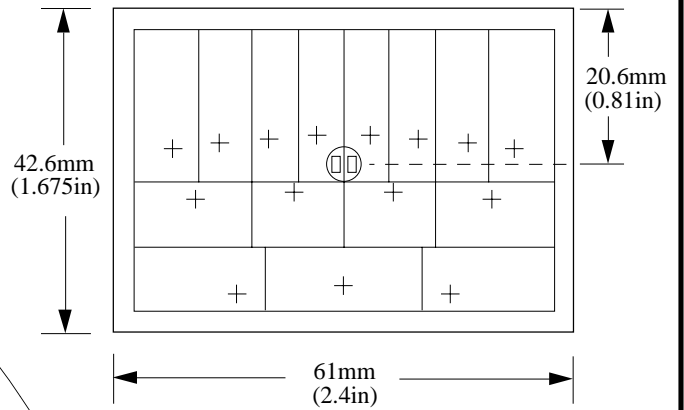

Figure 6

# WIDE ANGLE ARRAY

WA 1.2 GI 12 V5

FRONT VIEW:



TOP VIEW:

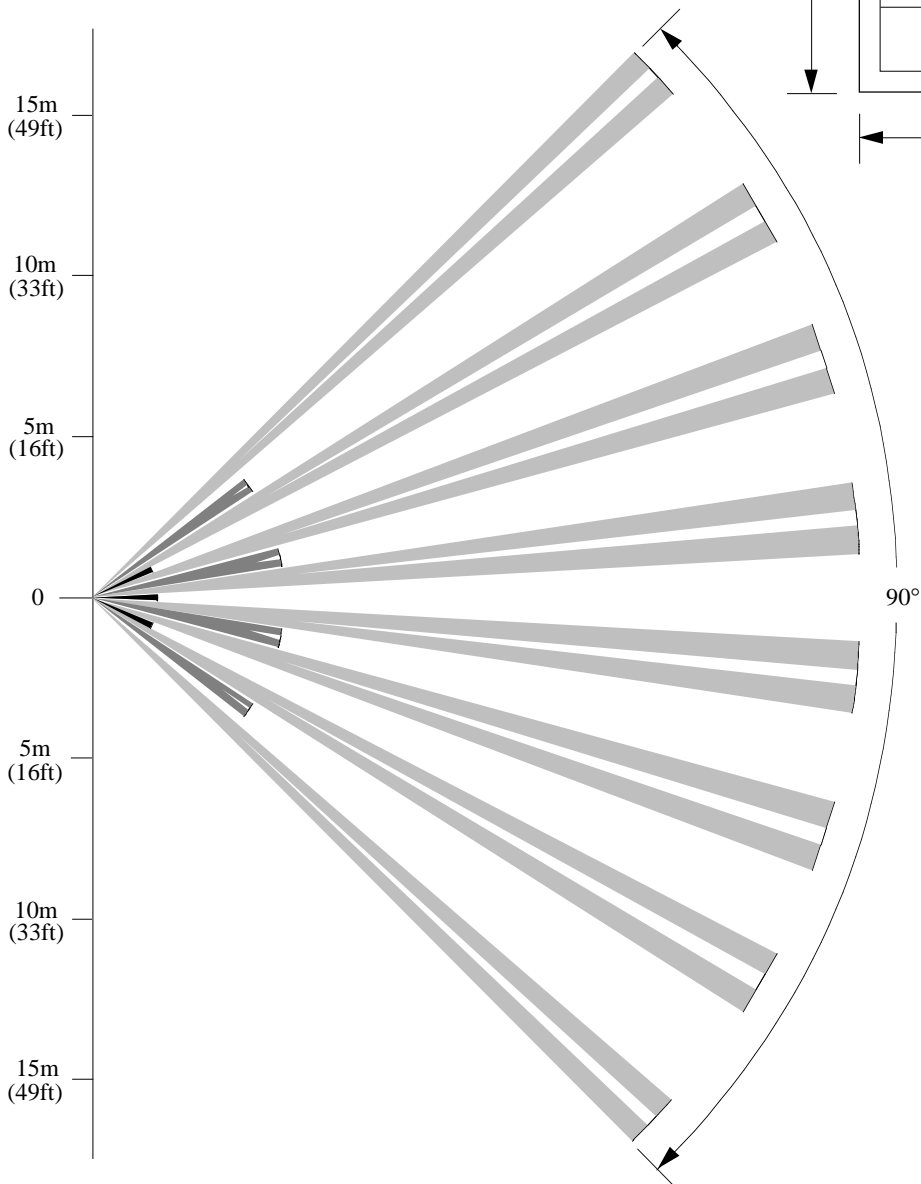

SIDE VIEW:

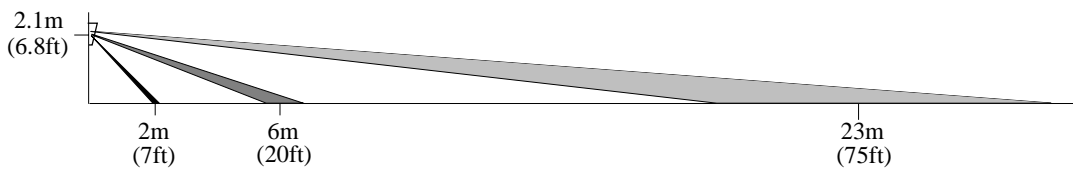
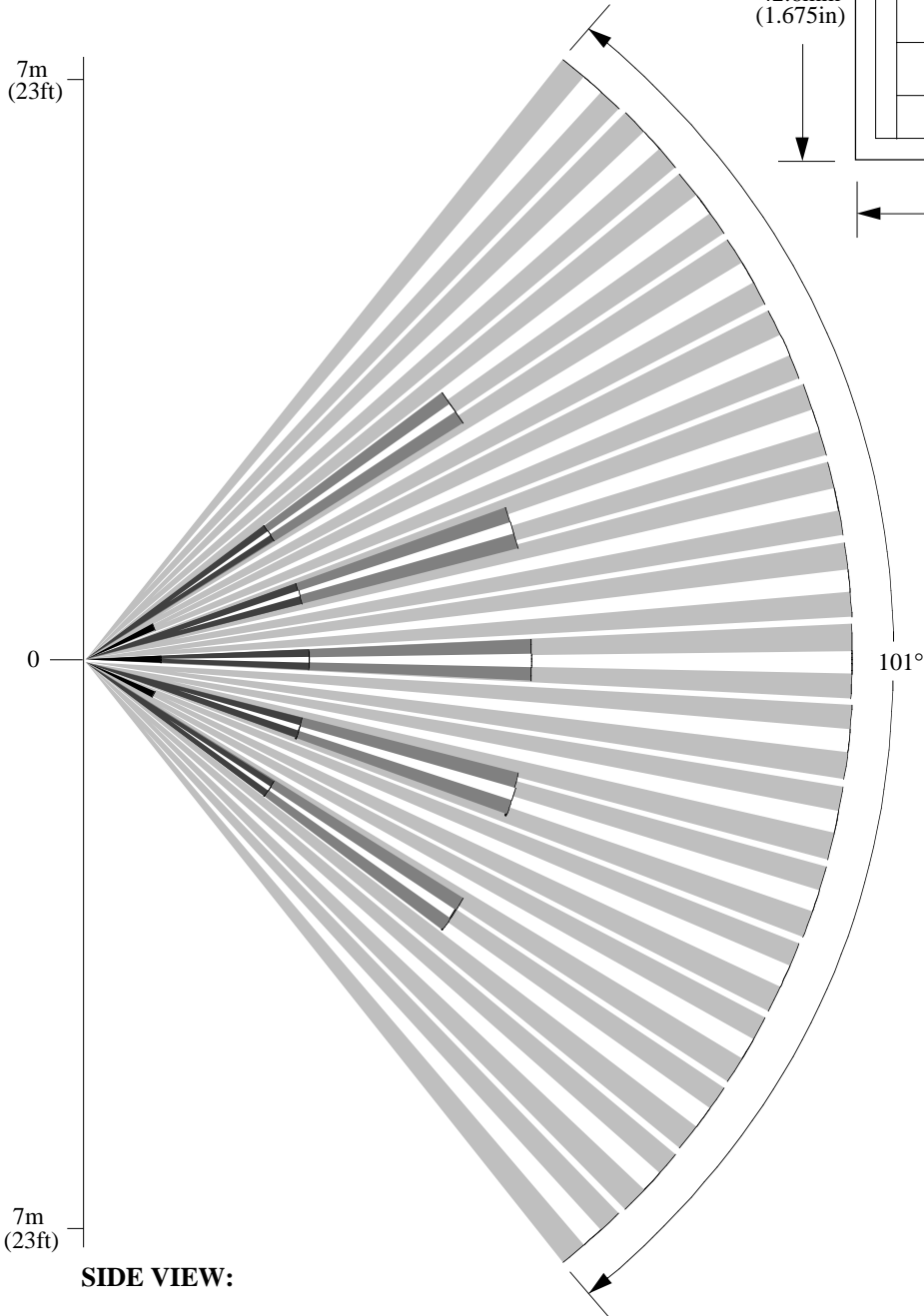

Figure 7

# DENSE WIDE ANGLE ARRAY

DWA 1.2 GI 12 V2

TOP VIEW:



FRONT VIEW:

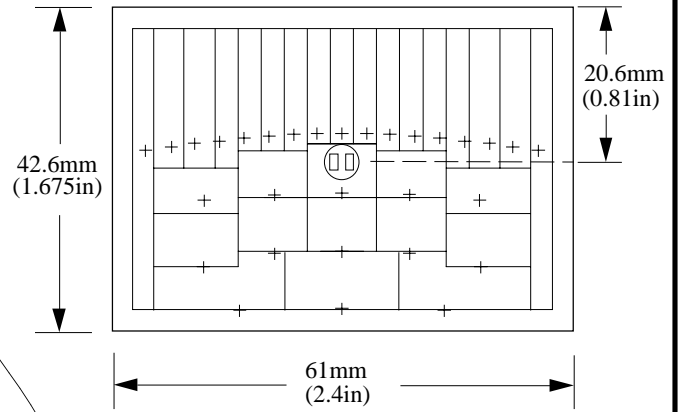

SIDE VIEW:

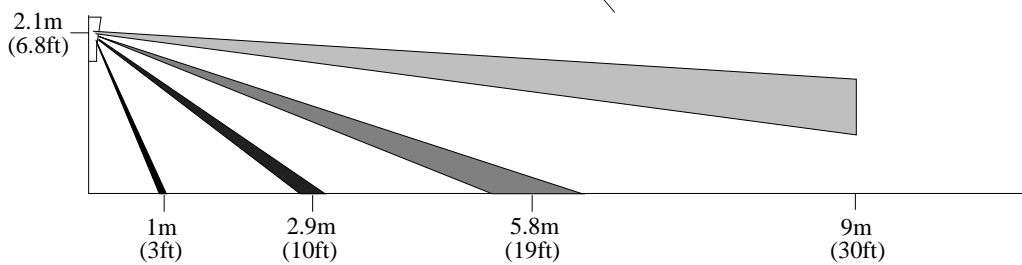

Figure 8



# DENSE WIDE ANGLE ARRAY

DWA 1.2 GI 12 V1

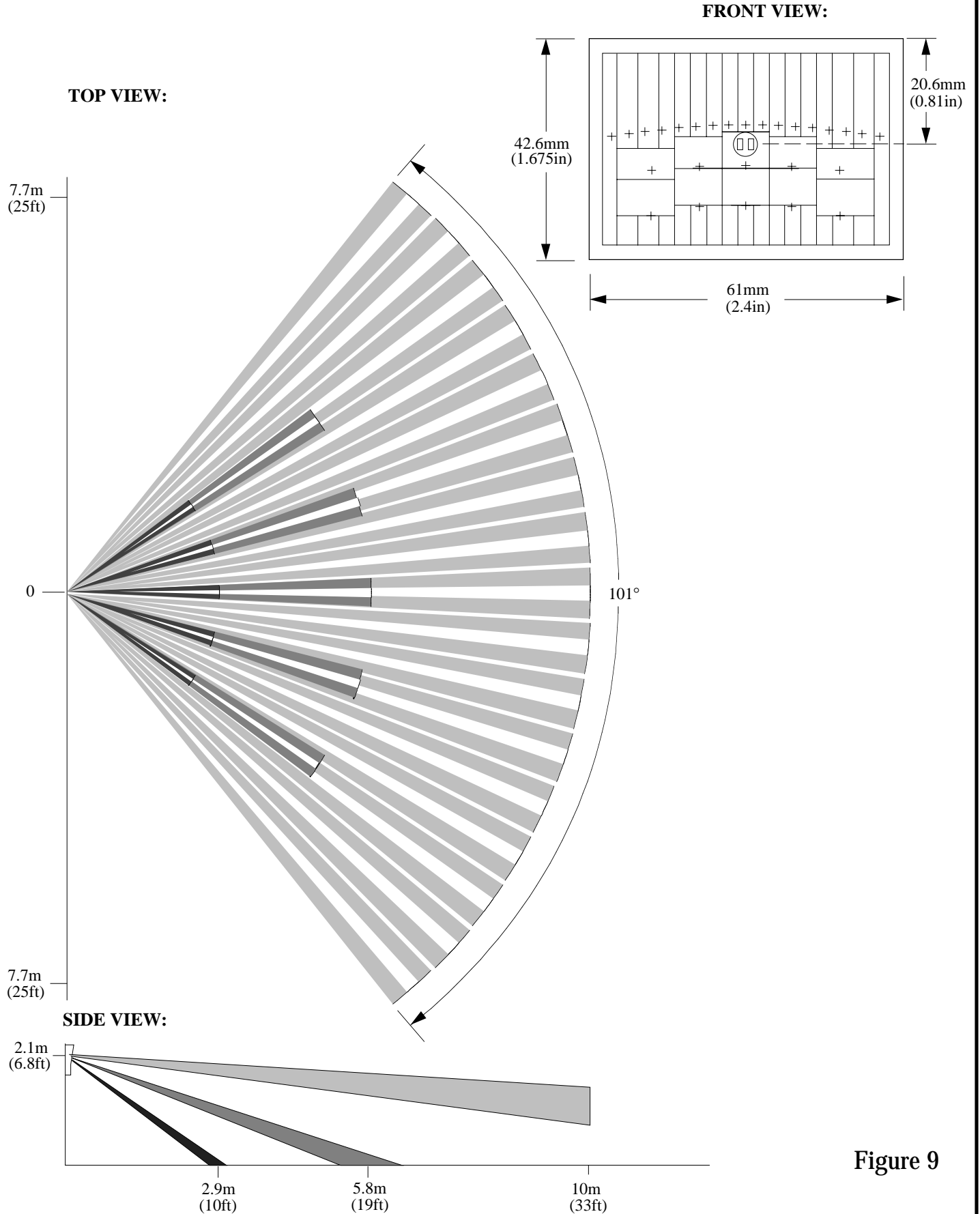
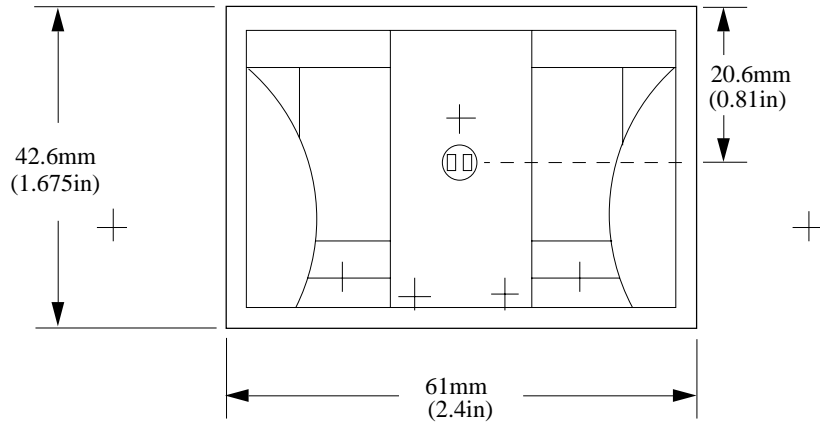

Figure 9

# LONG RANGE ARRAY

LR 1.2 GI 12 V1

## FRONT VIEW:



## TOP VIEW:

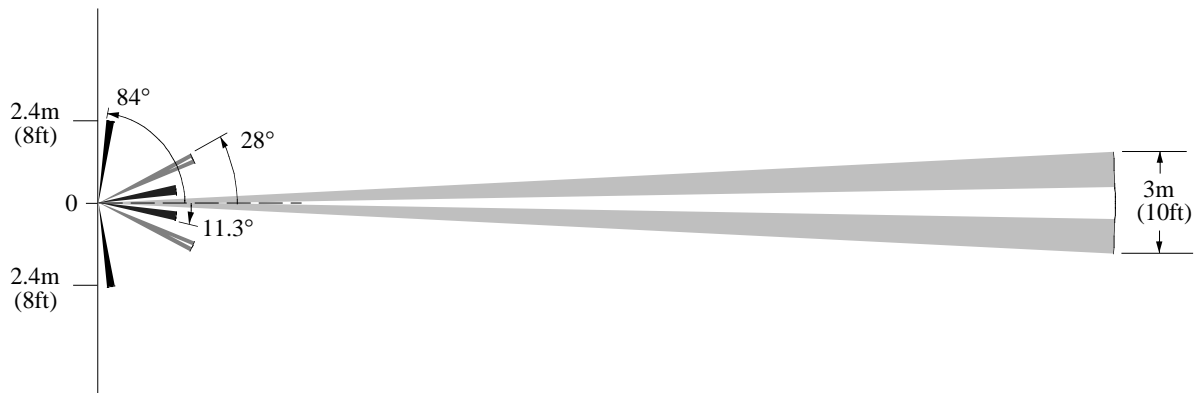

## SIDE VIEW:

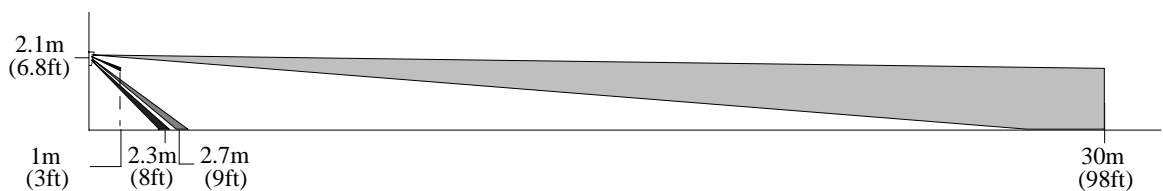
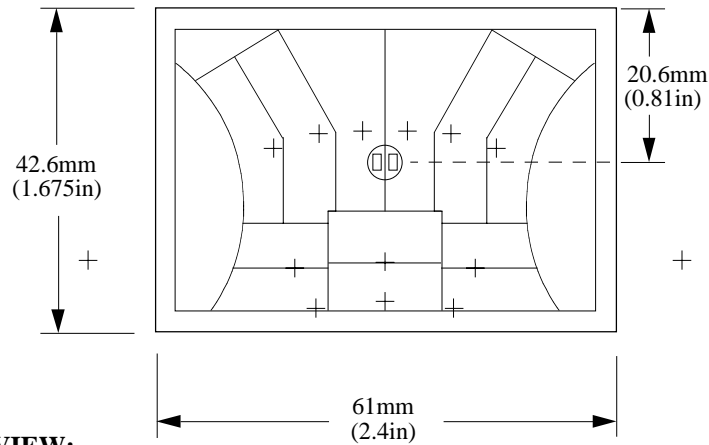

Figure 10

# LONG RANGE ARRAY

LR 1.2 GI 12 V2

## FRONT VIEW:



## TOP VIEW:

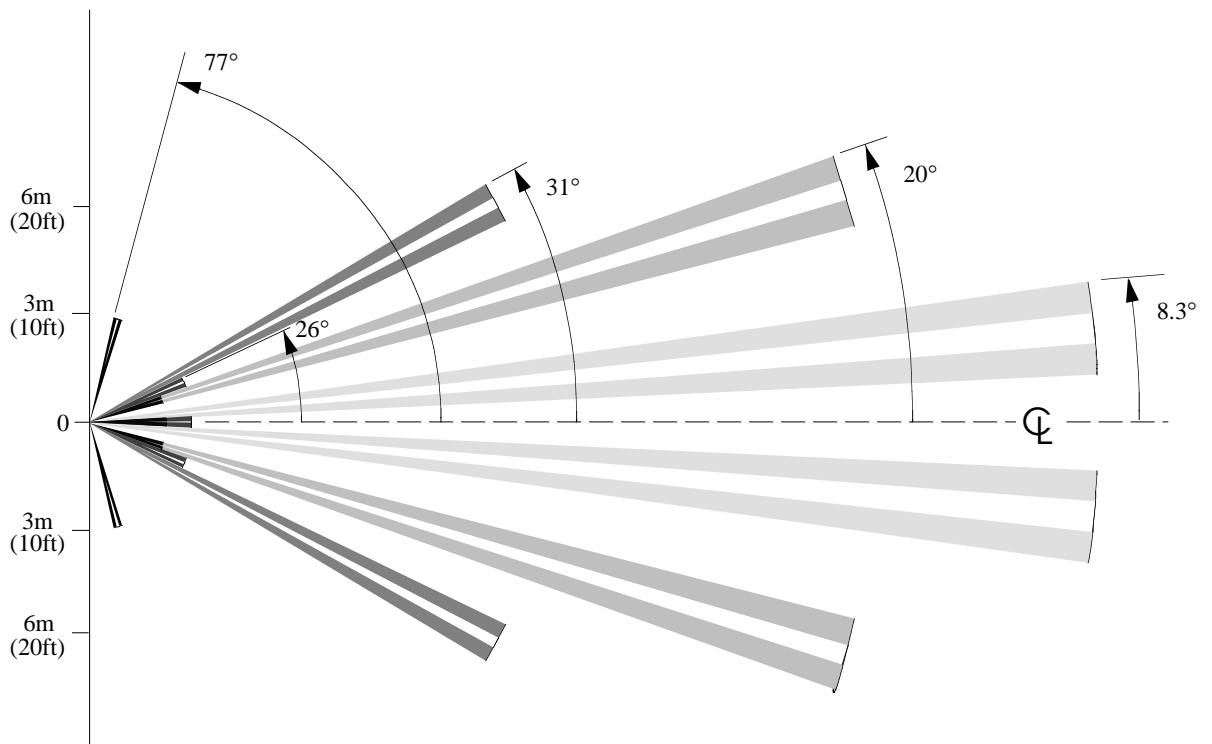

## SIDE VIEW:

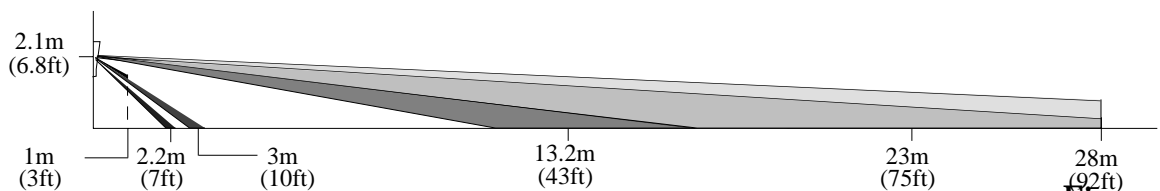
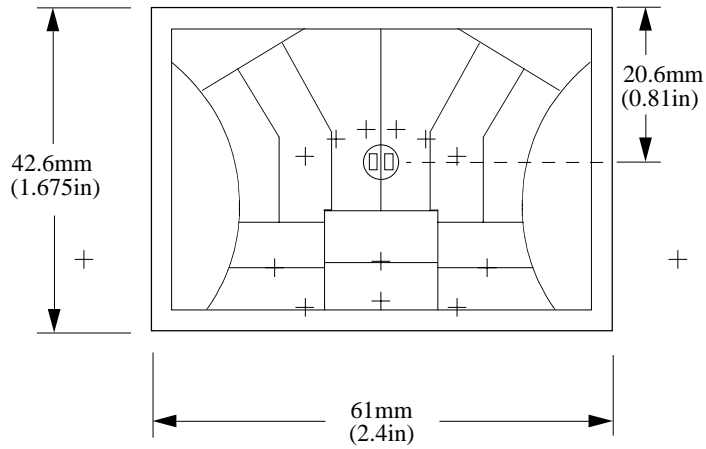

Figure 11

# LONG RANGE ARRAY

LR 1.2 GI 12 V3

## FRONT VIEW:



## TOP VIEW:

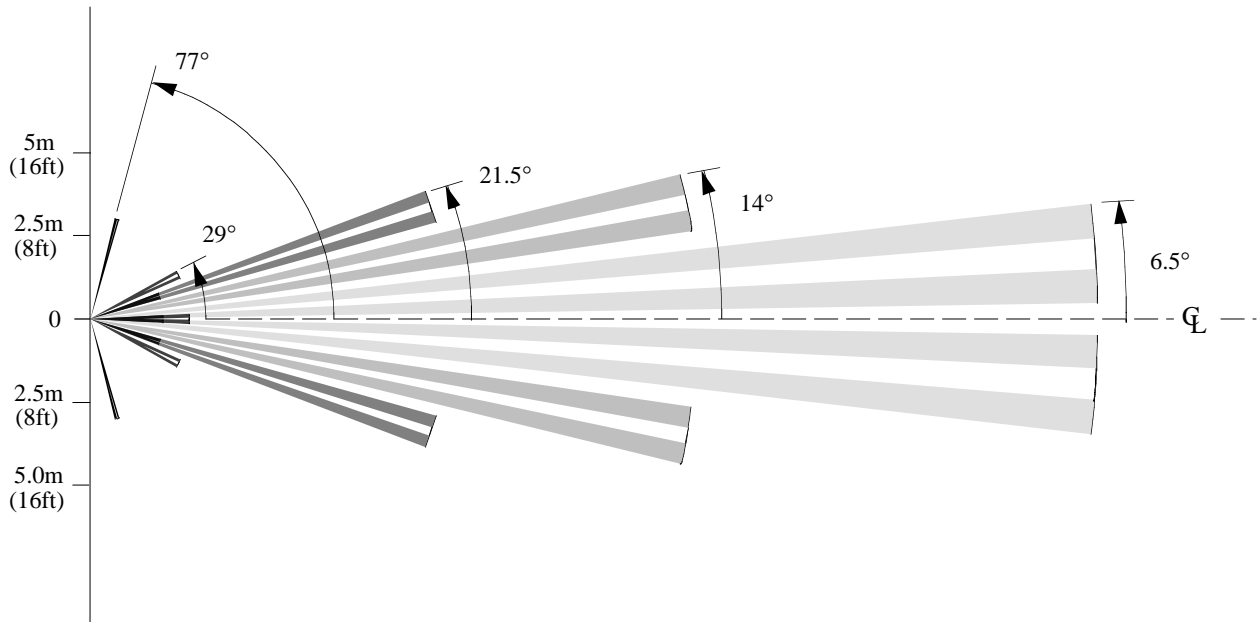

## SIDE VIEW:

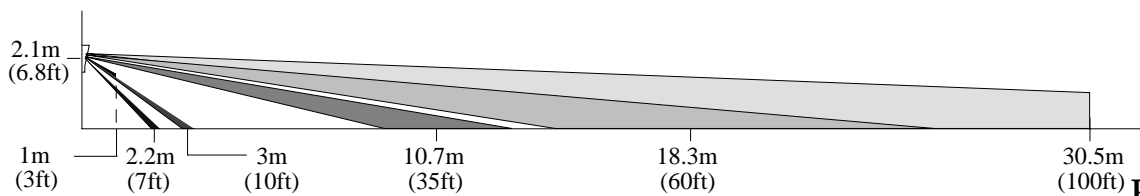

Figure 12

# EXTRA WIDE ANGLE ARRAY

EWA 1.2 GI 12 V1

FRONT VIEW:

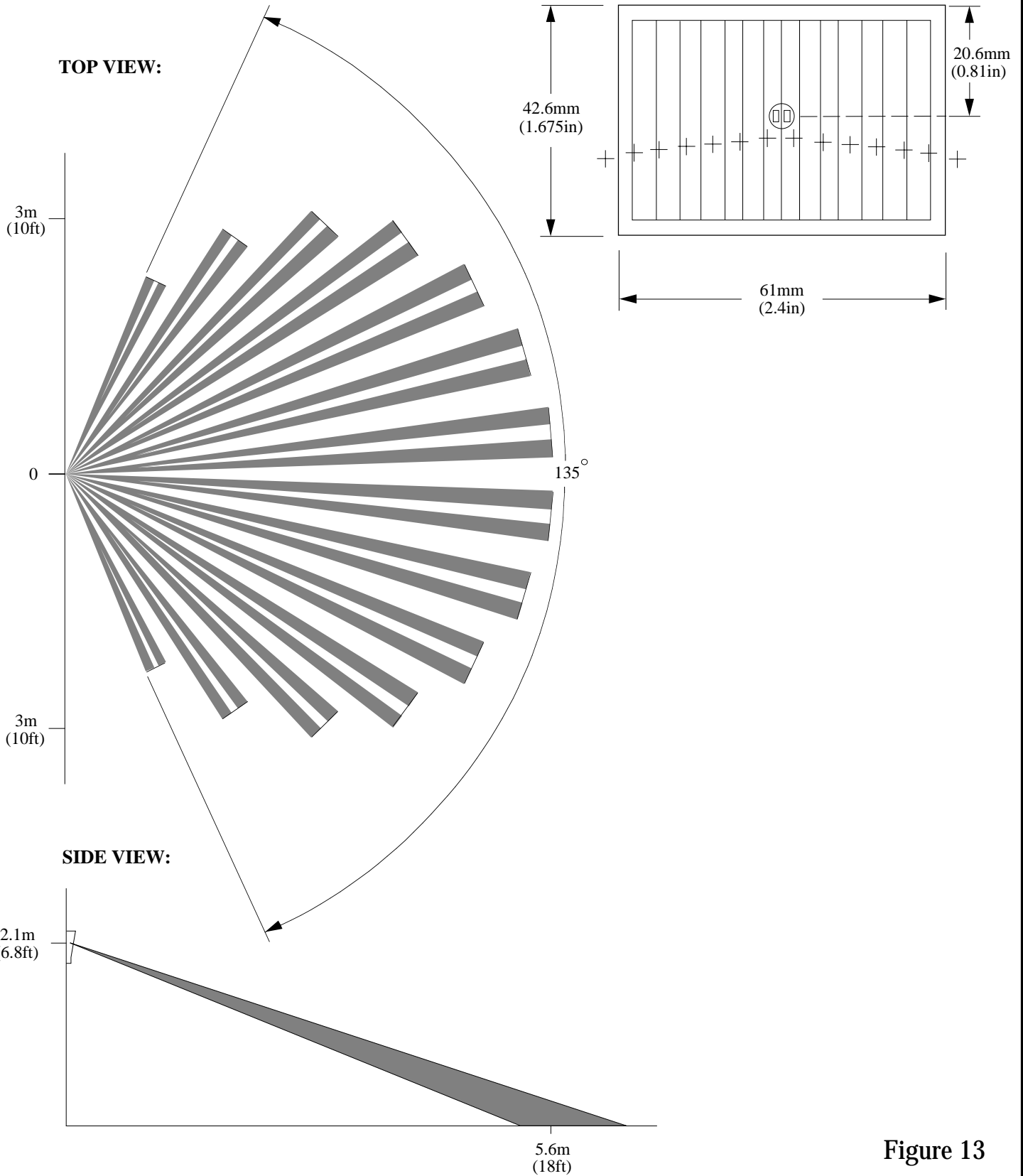
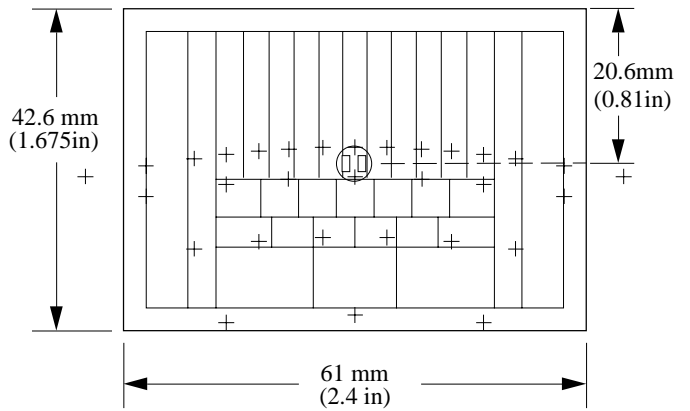

Figure 13

# EXTRA WIDE ANGLE ARRAY

EWA 1.2 GI 12 V2

FRONT VIEW:



TOP VIEW:

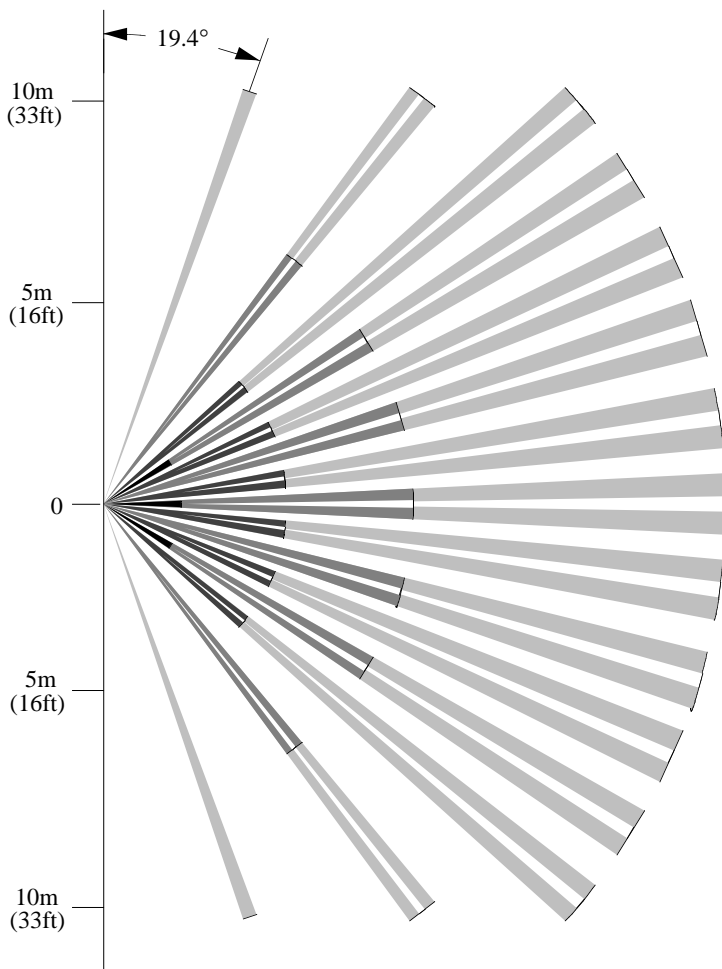

SIDE VIEW:

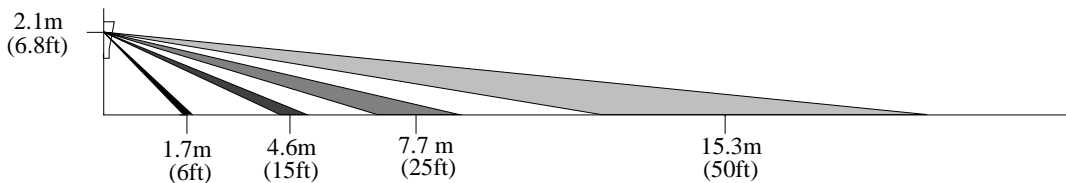

Figure 14

# EXTRA WIDE ANGLE ARRAY

EWA 1.2 GI 12 V3

FRONT VIEW:

TOP VIEW:

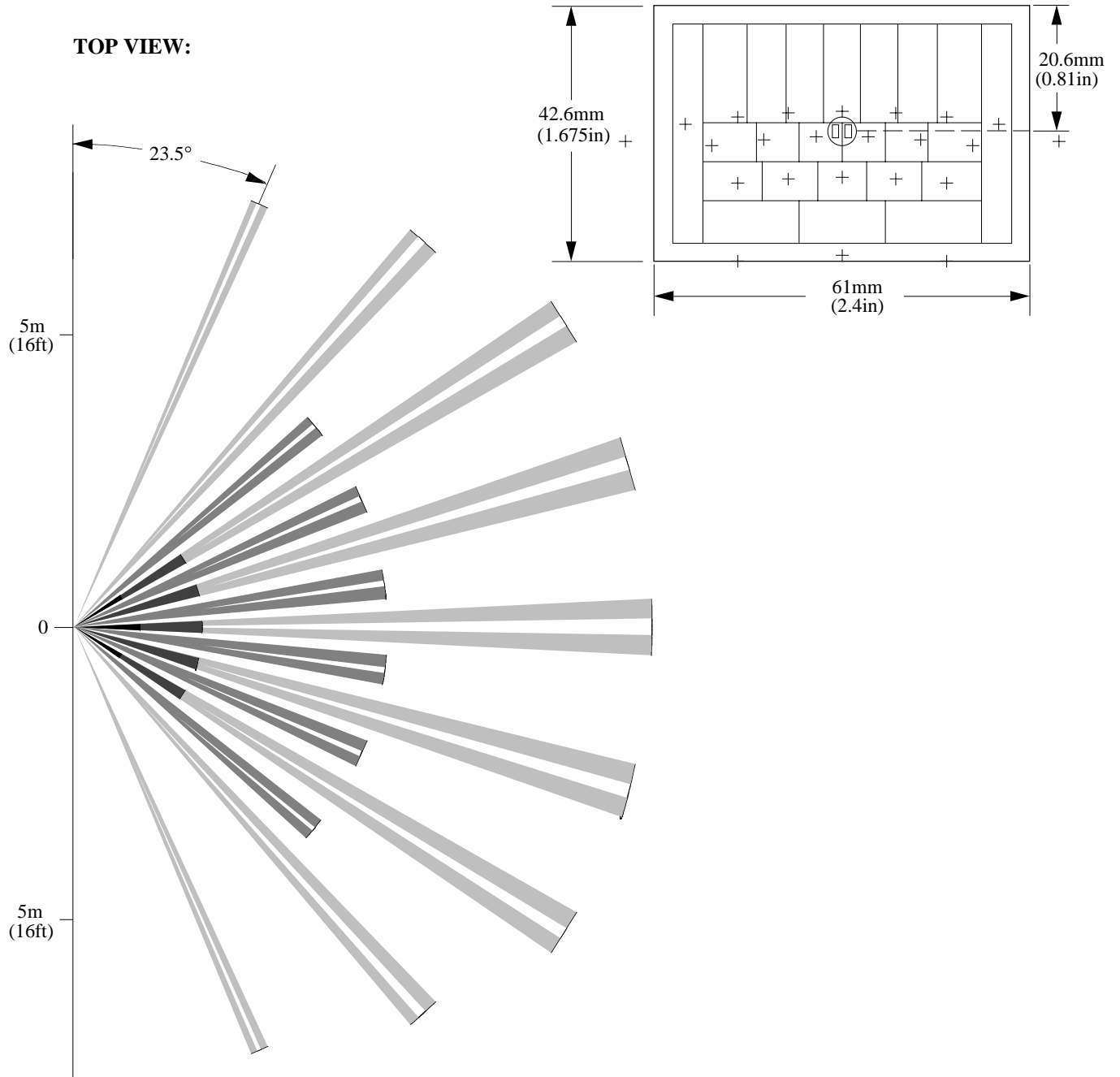

SIDE VIEW:

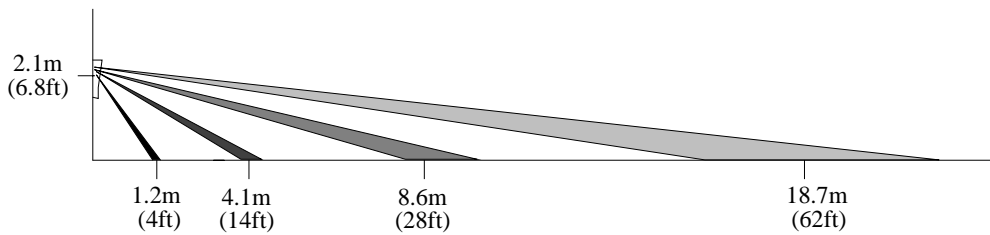
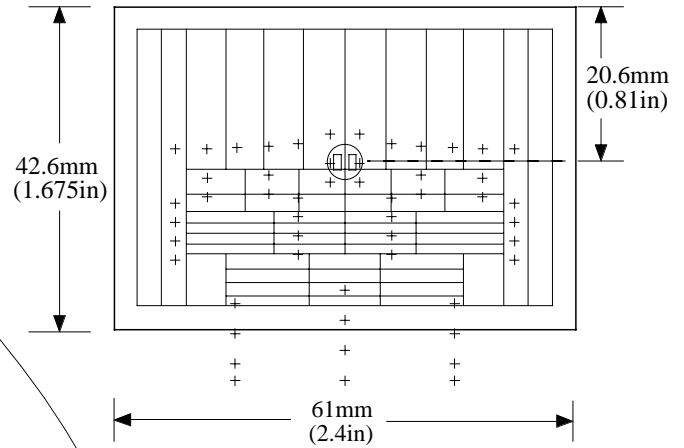

Figure 15

# WIDE ANGLE ARRAY

WP 1.2 GI 12 V1

FRONT VIEW:



TOP VIEW:

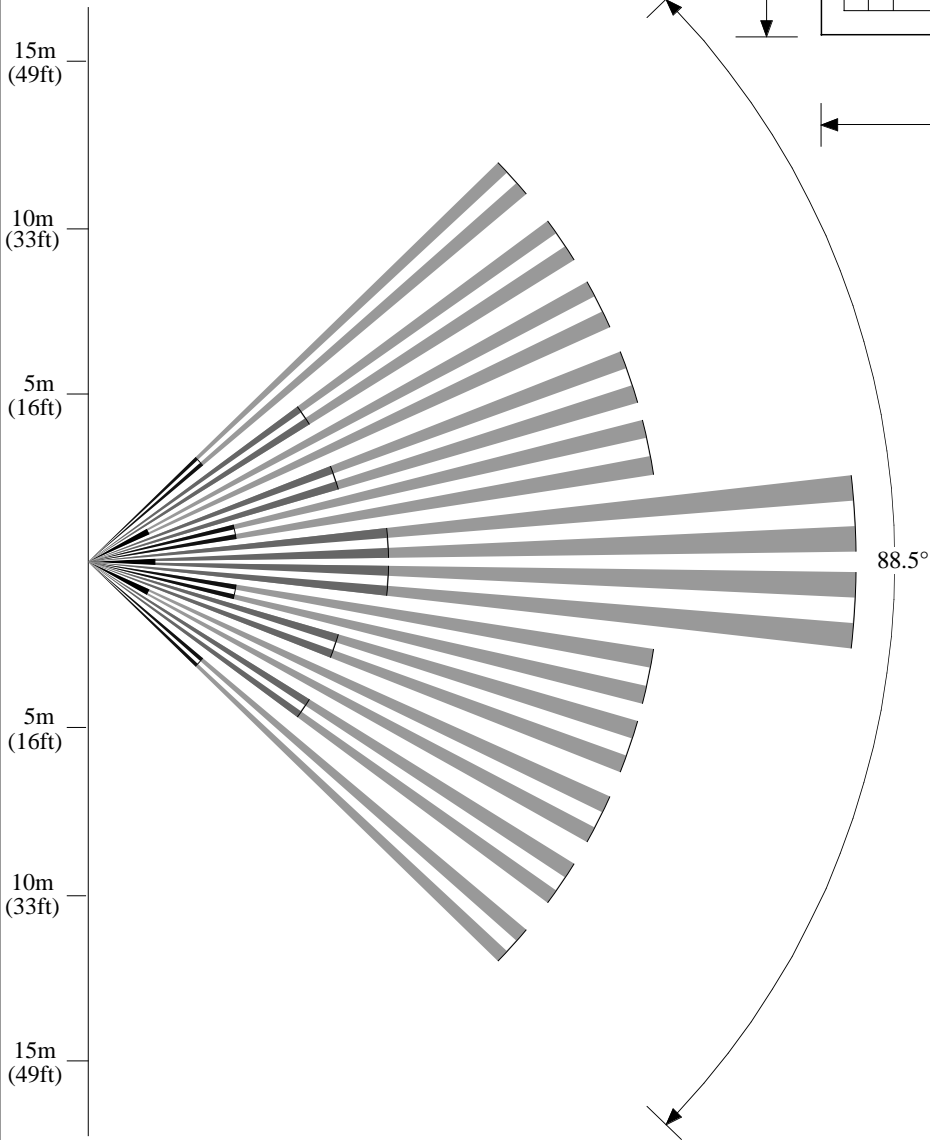

SIDE VIEW:

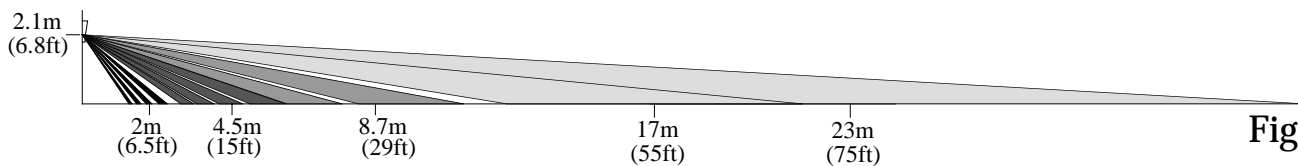

Figure 16



# Extra Wide Pet Immune

EWP 1.2 GI V1

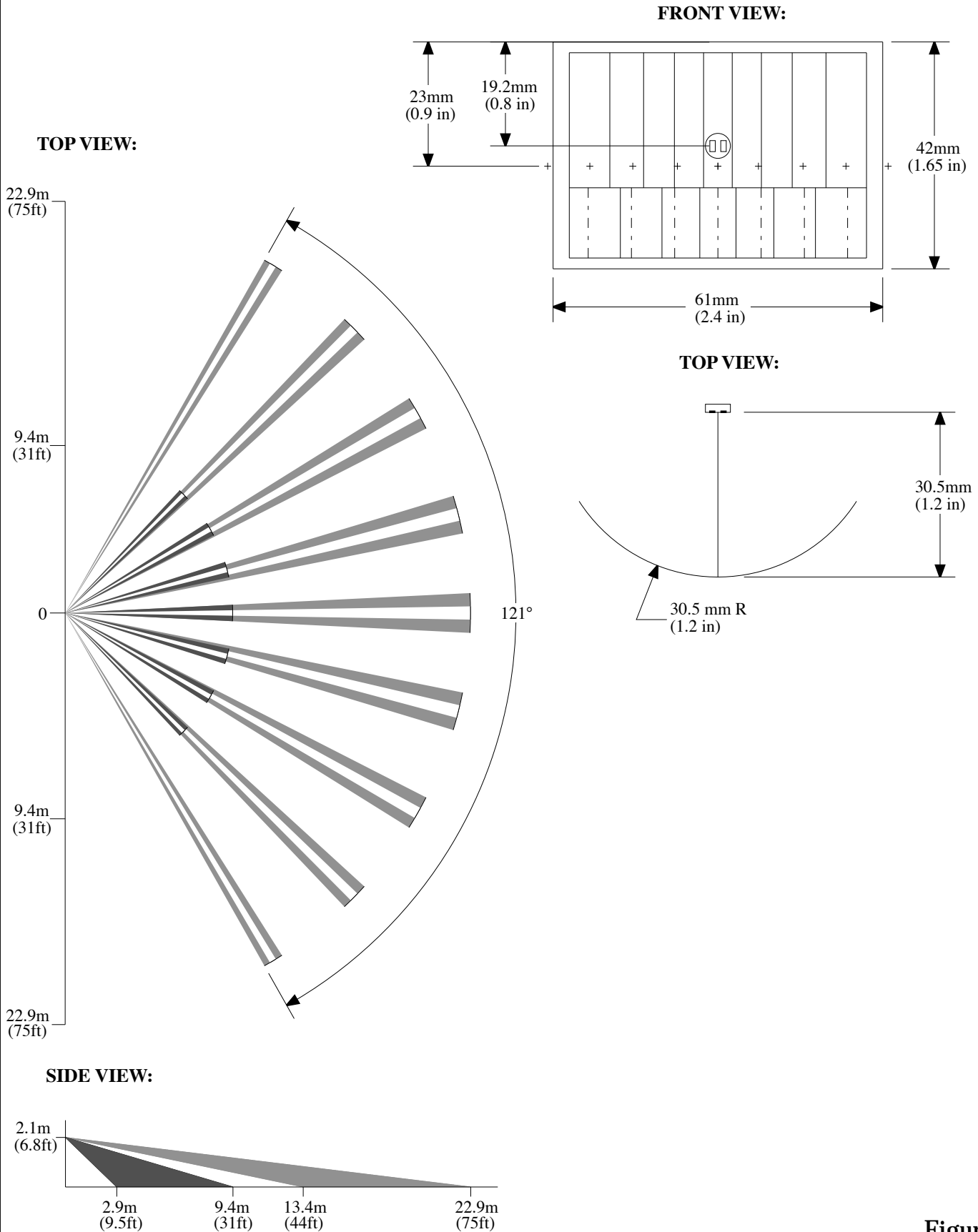
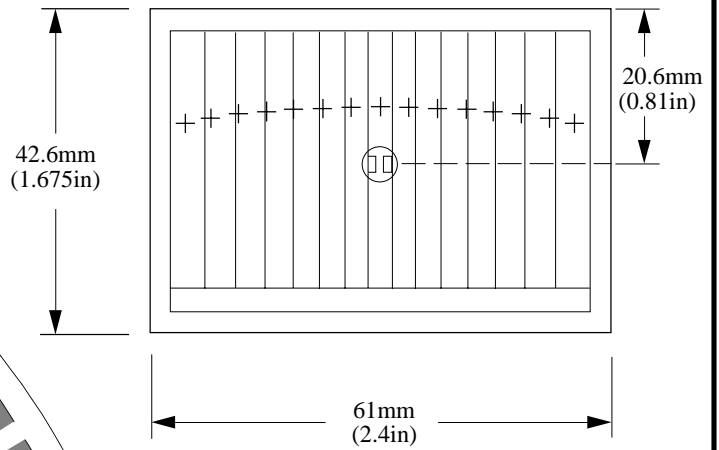

Figure 17

# ANIMAL ALLEY ARRAY

AA 1.2 GI 12 V1

FRONT VIEW:



TOP VIEW:

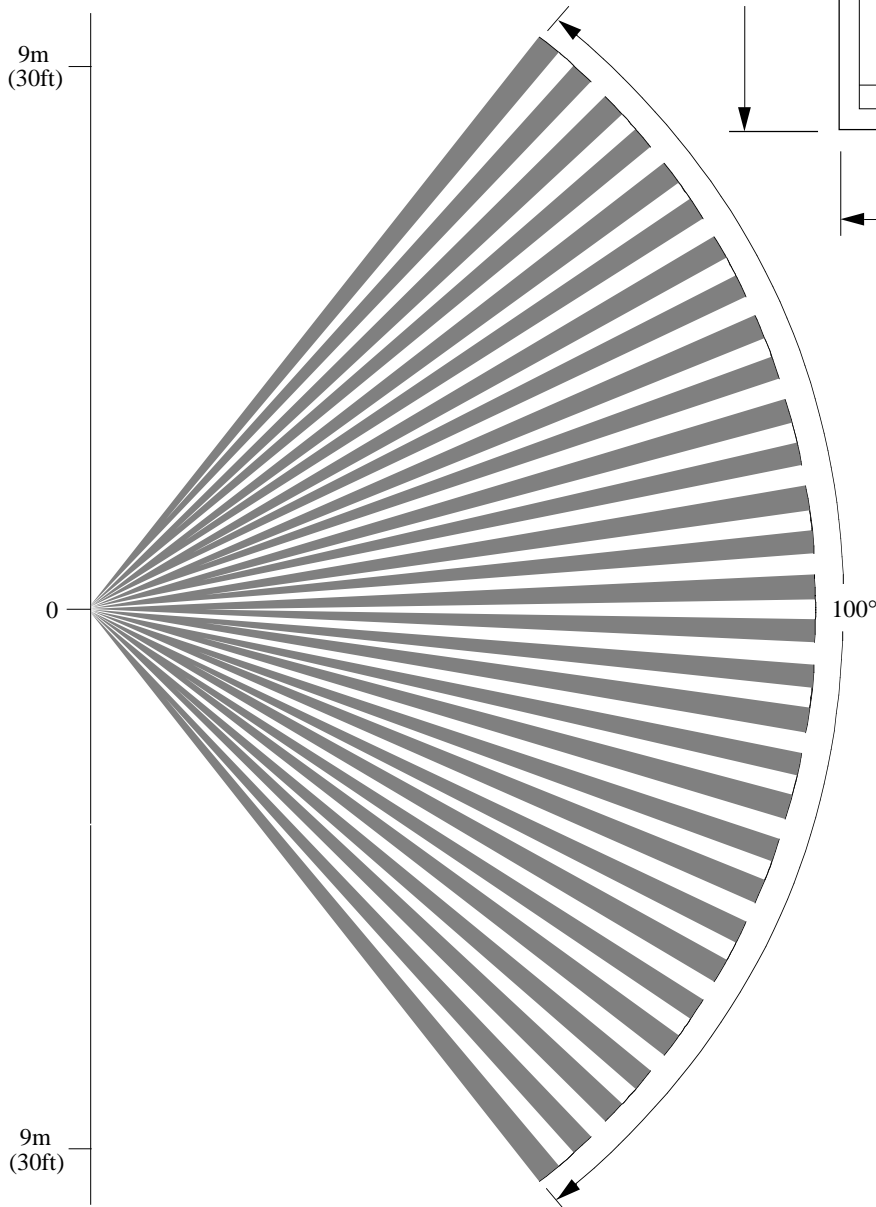

SIDE VIEW:

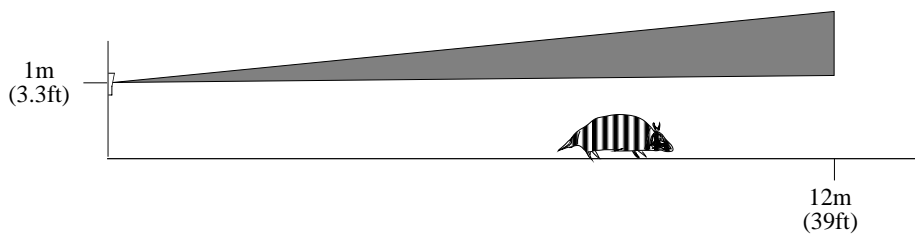

Figure 18

# ANIMAL ALLEY ARRAY

AA 1.2 GI V1

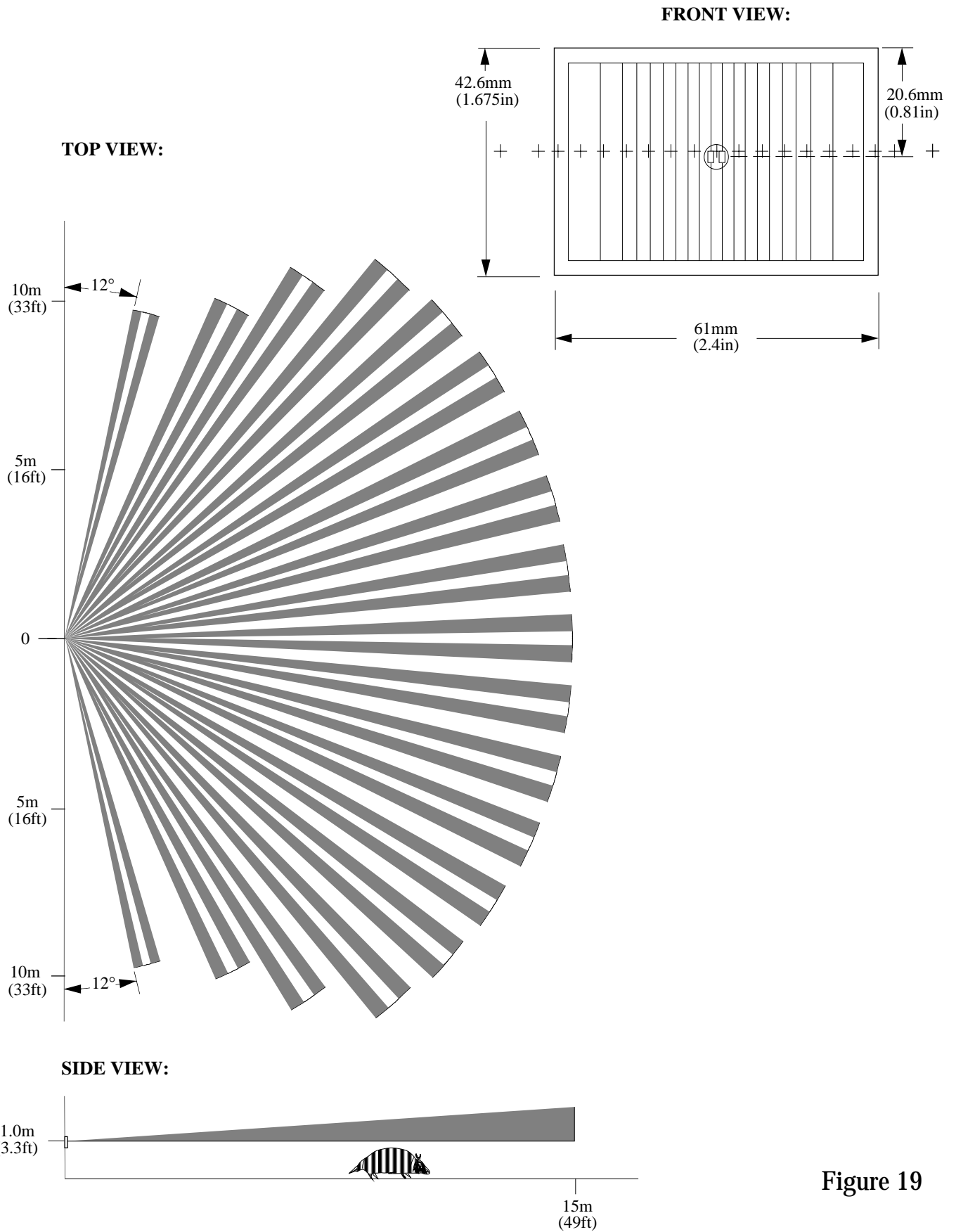

Figure 19

# ANIMAL ALLEY ARRAY

AA 1.2 GI V2

FRONT VIEW:

TOP VIEW:

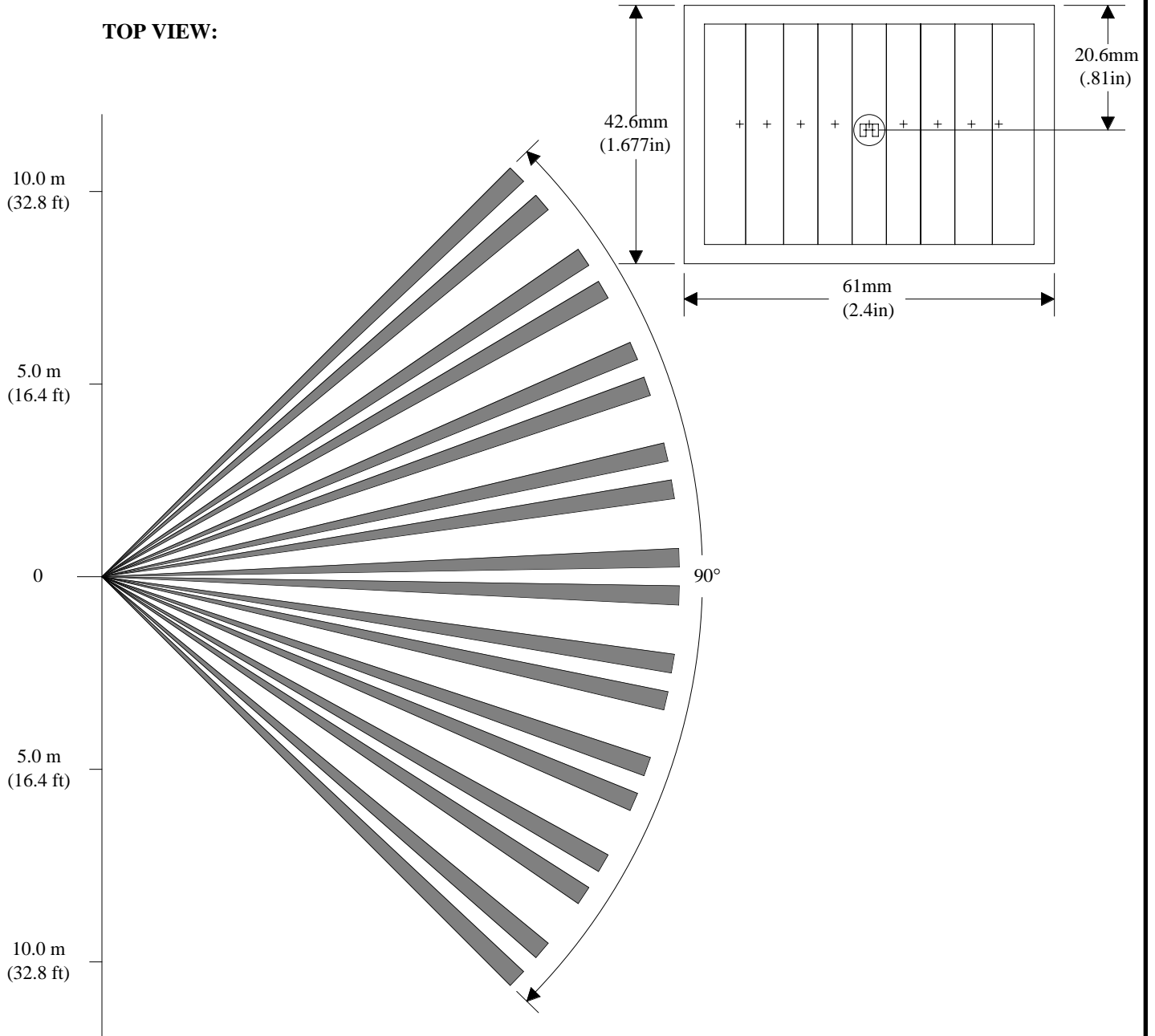

SIDE VIEW:

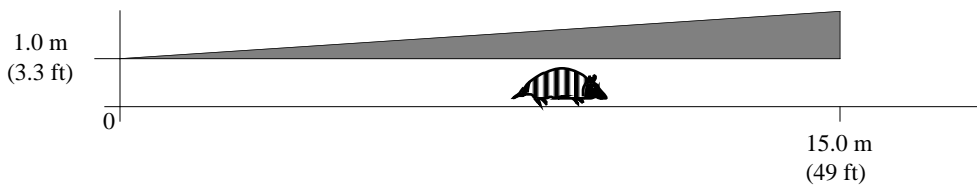
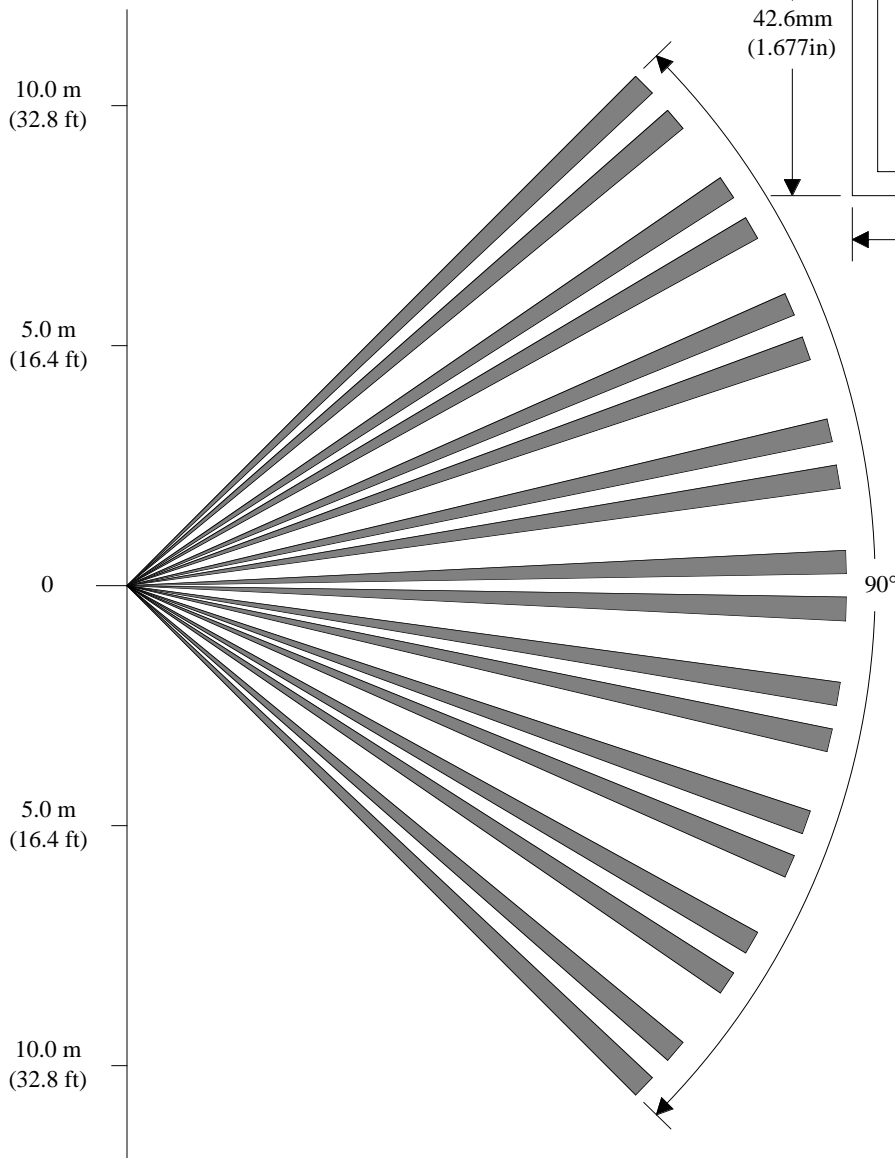

Figure 20

# ANIMAL ALLEY ARRAY

AA 1.2 GI V3

TOP VIEW:



FRONT VIEW:

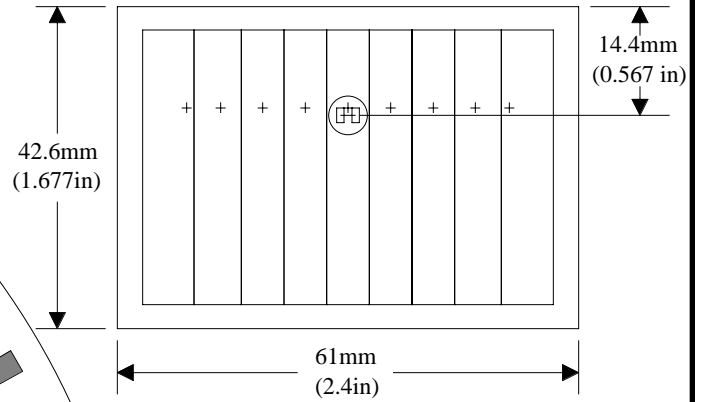

SIDE VIEW:

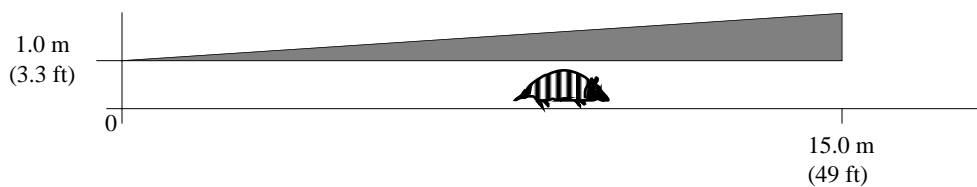
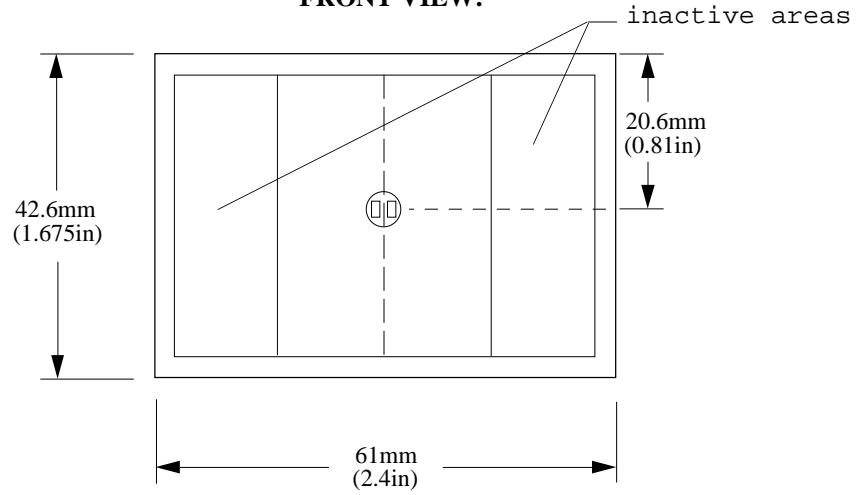

Figure 21

# VERTICAL BARRIER ARRAY

VB 1.2 GI V1

FRONT VIEW:



TOP VIEW:

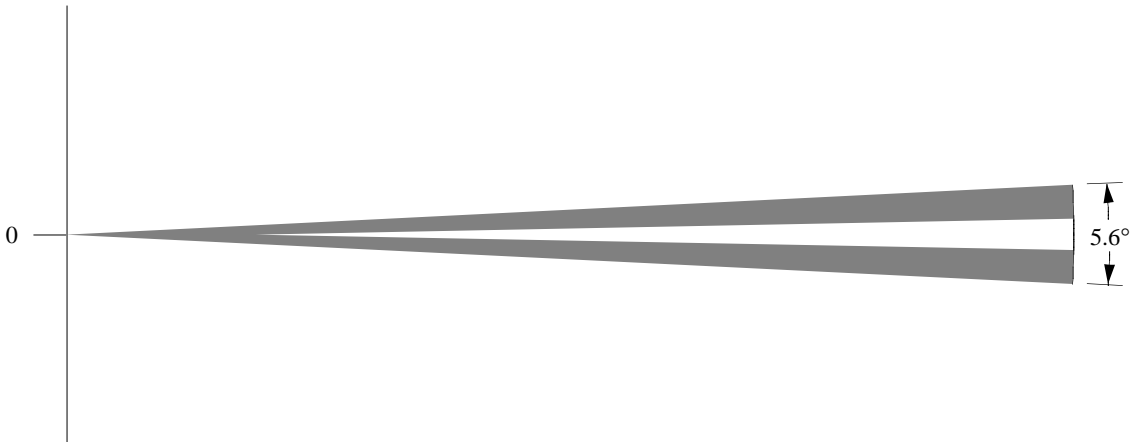

SIDE VIEW:

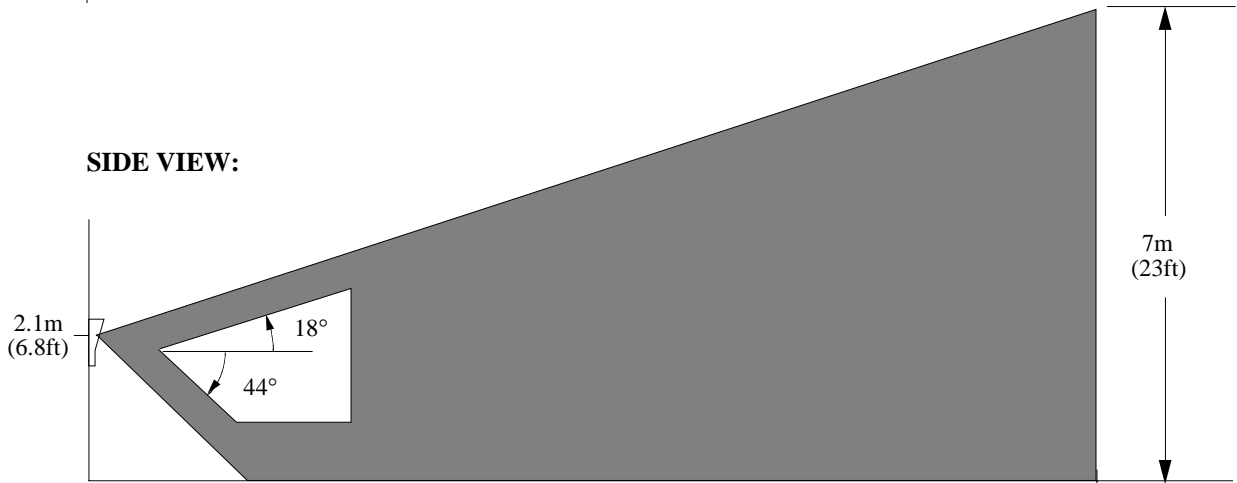
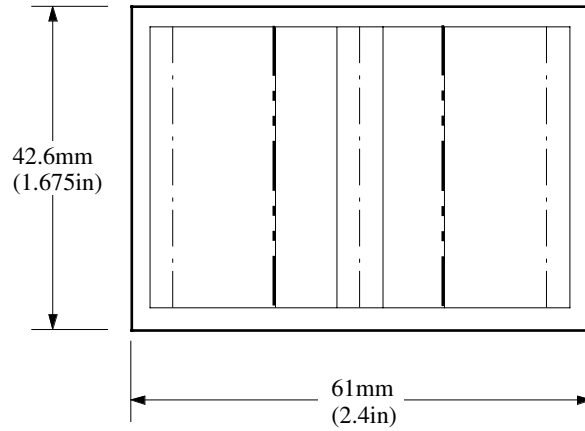

Figure 22

# VERTICAL BARRIER ARRAY

VB 1.2 GI V2

FRONT VIEW:



TOP VIEW:

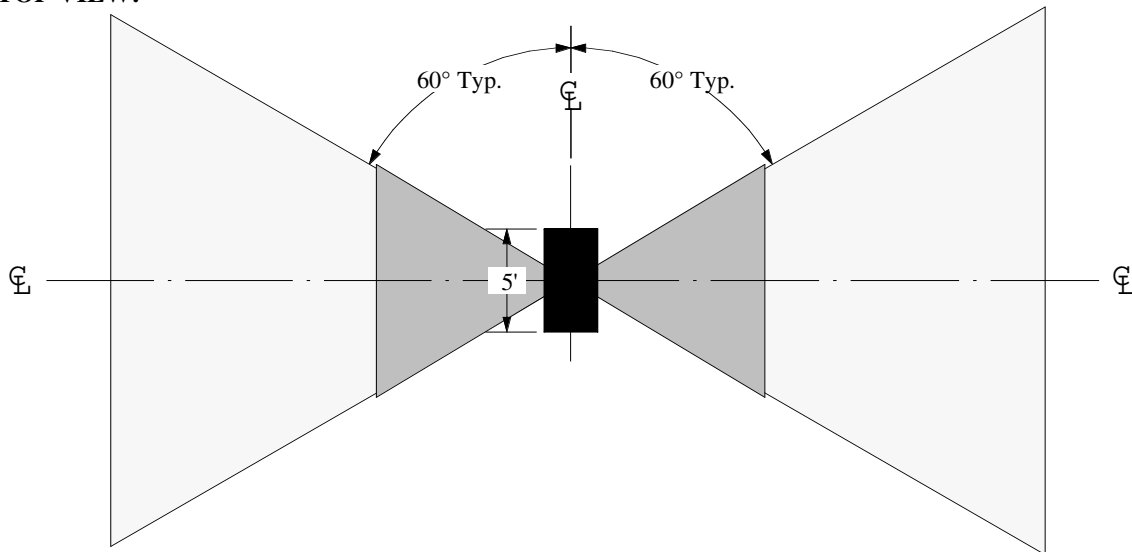

SIDE VIEW:

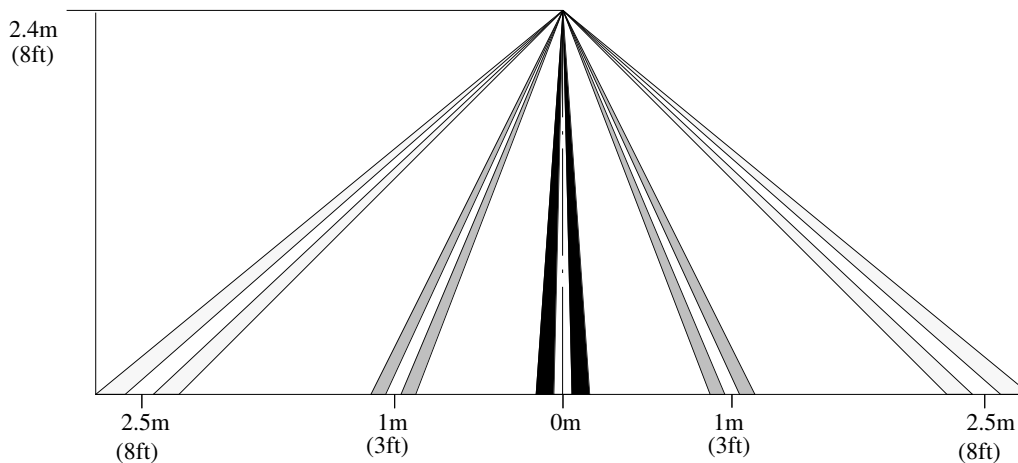
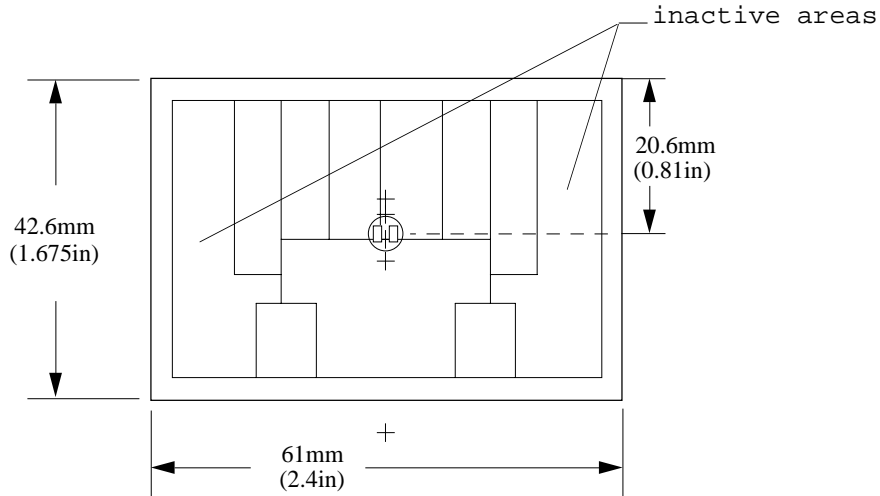

Figure 23

# VERTICAL BARRIER ARRAY

VB 1.2 GI 12 V1

## FRONT VIEW:



## TOP VIEW:

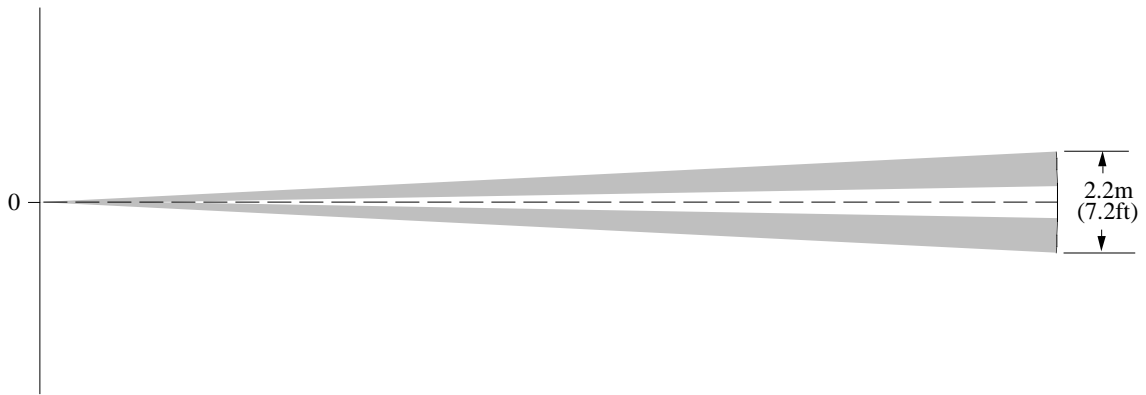

## SIDE VIEW:

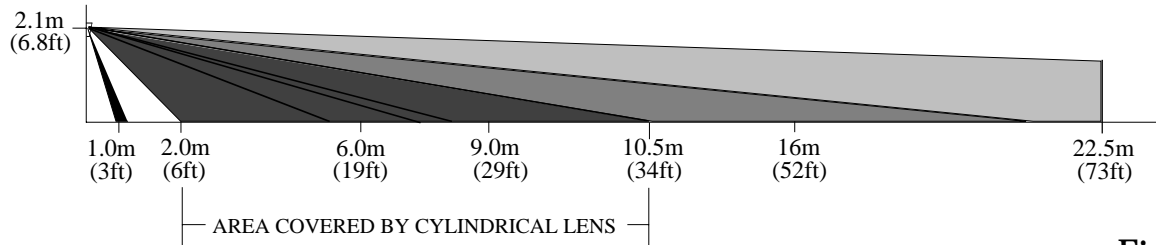

Figure 24



# WIDE ANGLE ARRAY

WA 1.2 GI 12 V4  
NOT INCLINED DOWNWARD

## FRONT VIEW:

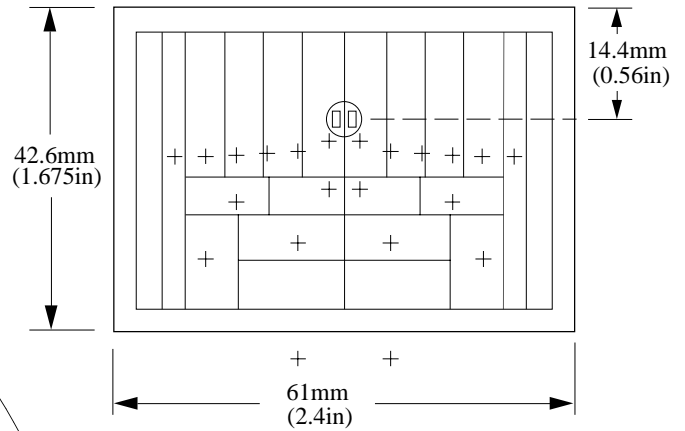

## TOP VIEW:

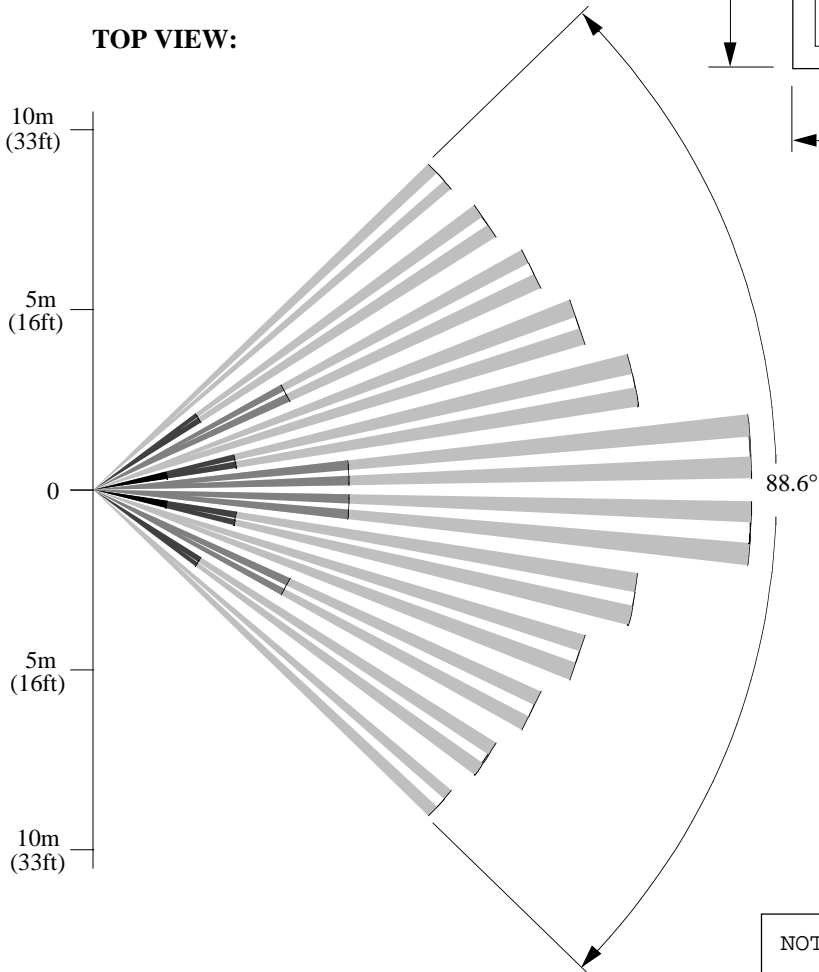

## SIDE VIEW:

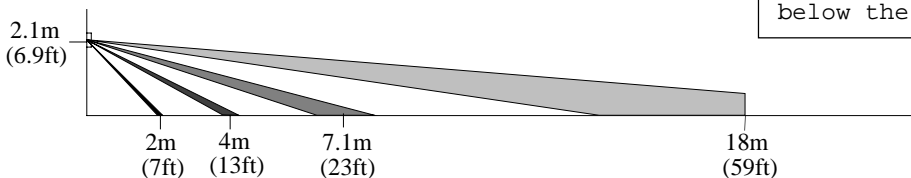

NOTE: this drawing shows the pattern produced by this array when the array is curved at a radius of 1.2 inches (30.5mm) but not inclined downward, and the detector centerline is at a distance of 0.56 inches (14.4mm) below the top edge of the top border.

Figure 25

# EXTRA WIDE ANGLE ARRAY

EWA 1.2 GI 12 V3

NOT INCLINED DOWNWARD

FRONT VIEW:

TOP VIEW:

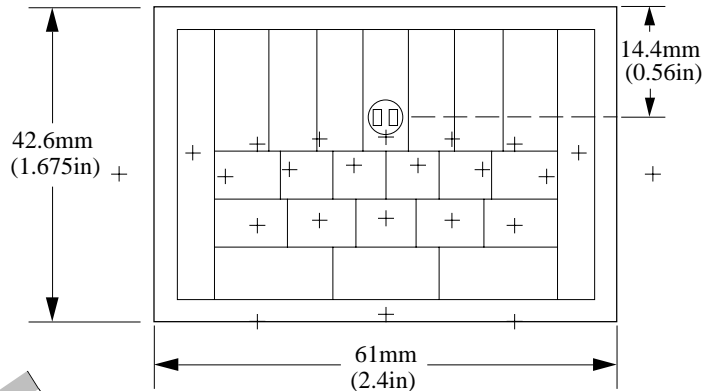
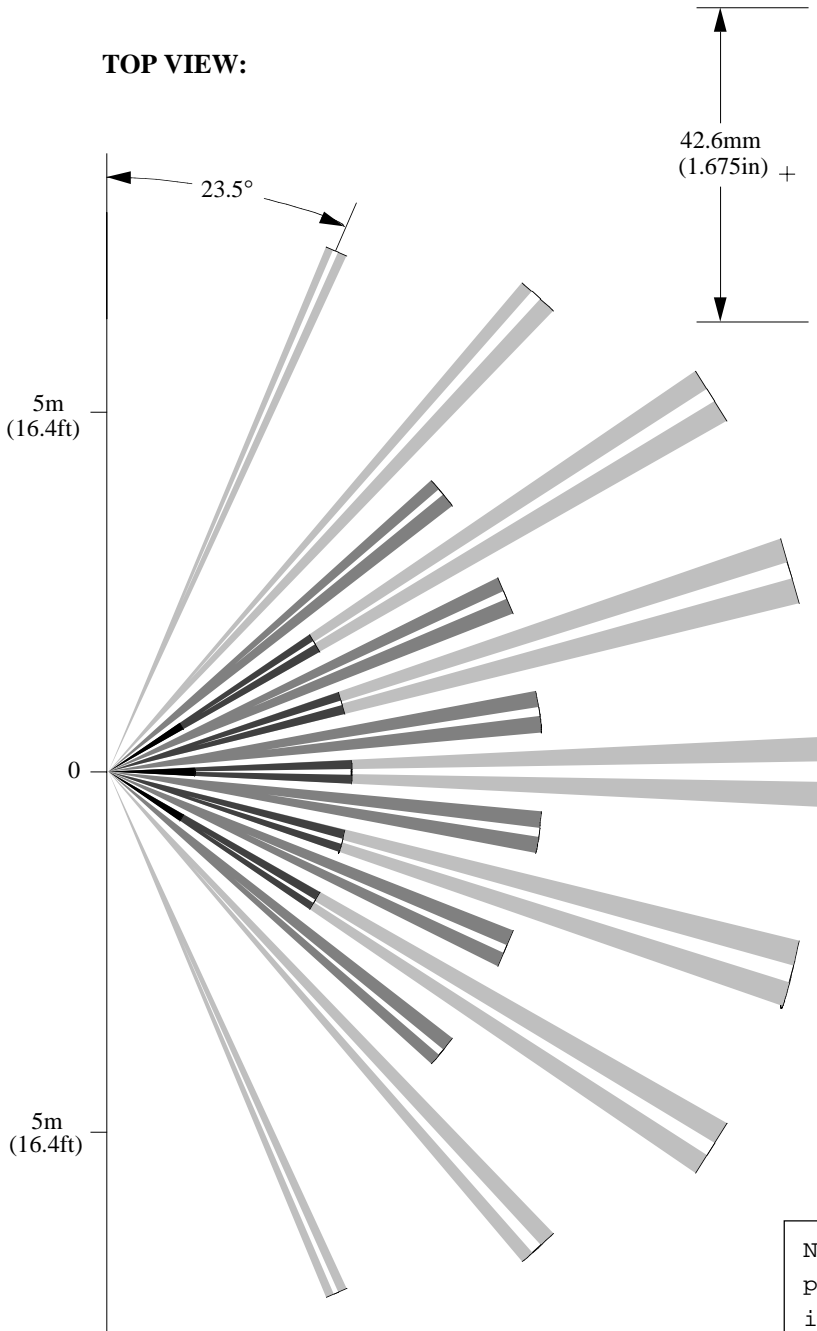

SIDE VIEW:

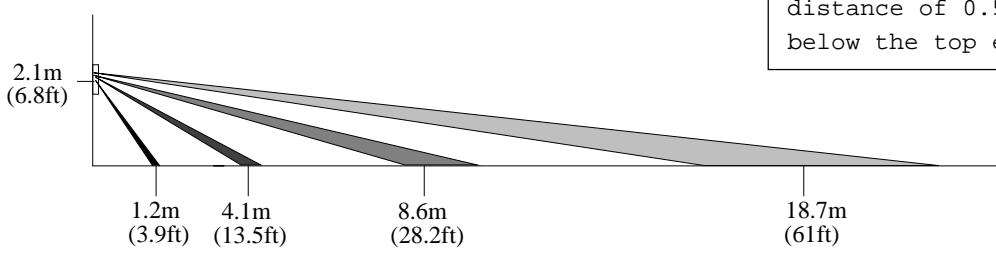

NOTE: this drawing shows the pattern produced by this array when the array is curved at a radius of 1.2 inches (30.5mm) but not inclined downward, and the detector centerline is at a distance of 0.56 inches (14.4mm) below the top edge of the top border.

Figure 26

# LONG RANGE ARRAY

LR 1.2 GI 12 V3  
NOT INCLINED DOWNWARD

## FRONT VIEW:

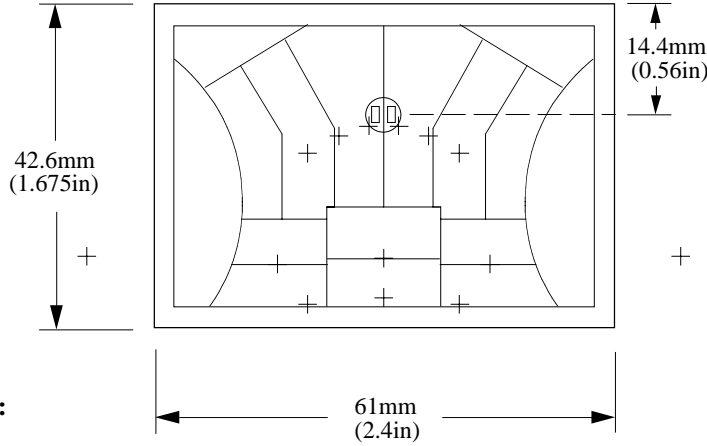

## TOP VIEW:

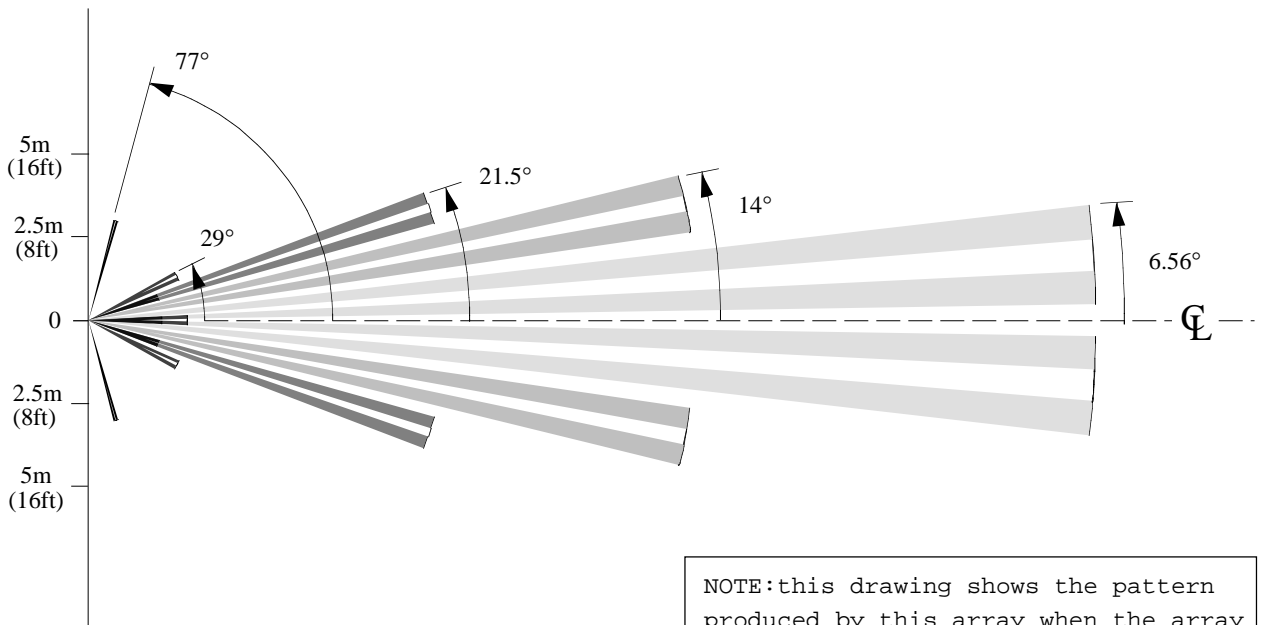

NOTE: this drawing shows the pattern produced by this array when the array is curved at a radius of 1.2 inches (30.5mm) but not inclined downward, and the detector centerline is at a distance of 0.56 inches (14.4mm) below the top edge of the top border.

## SIDE VIEW:

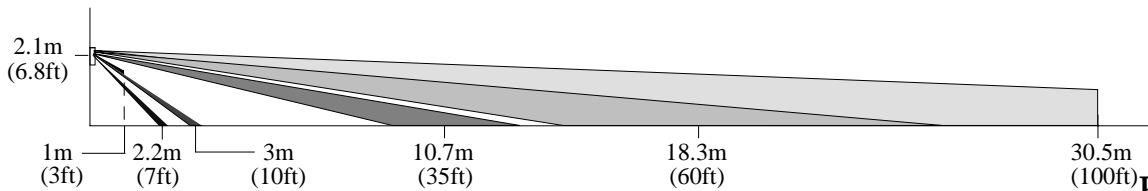
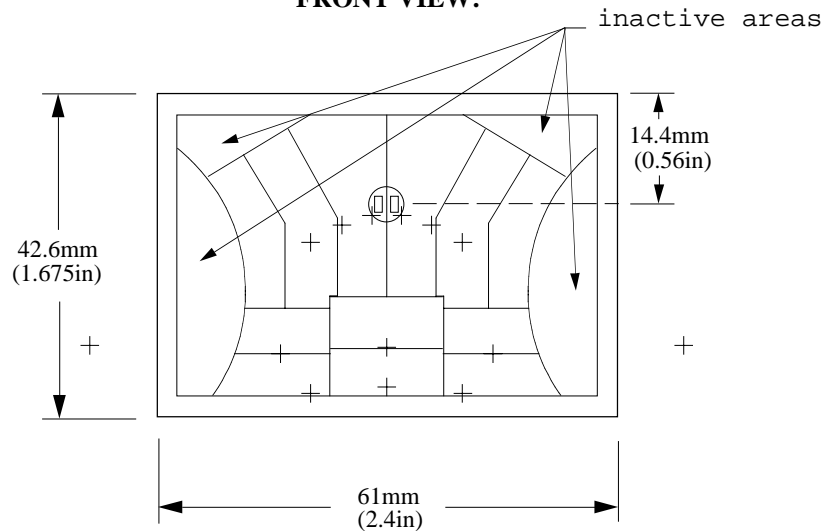

Figure 27

# LONG RANGE ARRAY

LR 1.2 GI 12 V3  
MOUNTED FLAT

FRONT VIEW:



TOP VIEW:

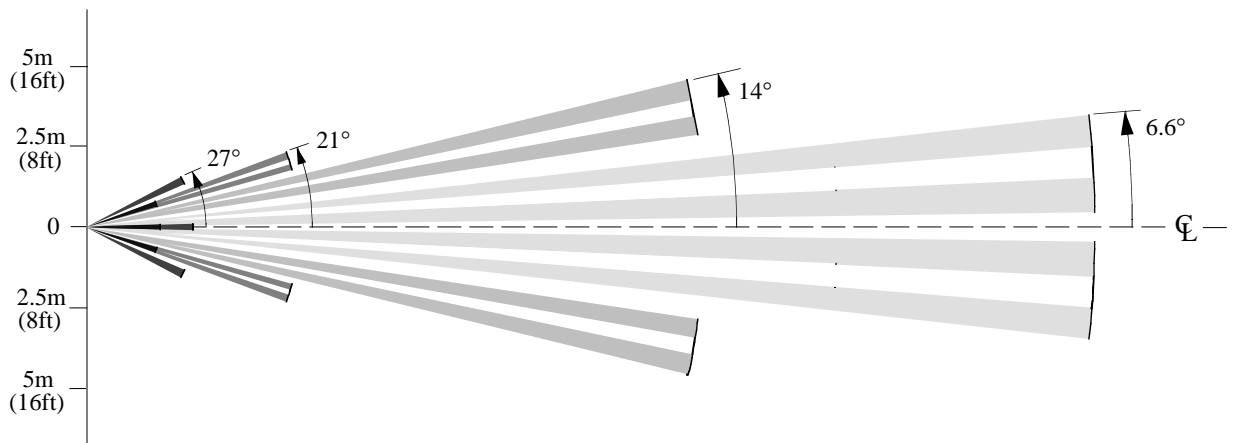

NOTE: this drawing shows the pattern produced by this array when the array is held flat at a distance of 1.2 inches (30.5mm) from the detector, but not inclined downward, and the detector centerline is at a distance of 0.56 inches (14.4mm) below the top edge of the top border.

SIDE VIEW:

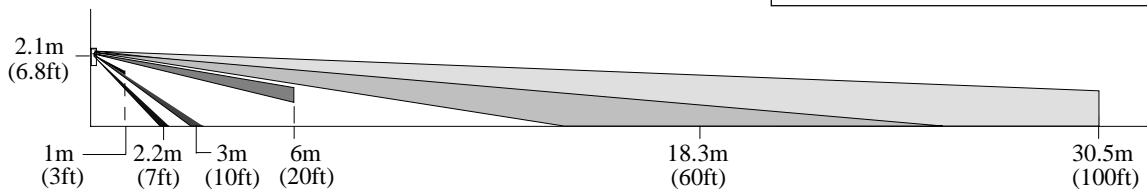

Figure 28

# EXTRA WIDE ANGLE ARRAY

EWA 1.2 GI 12 V2

MOUNTED FLAT

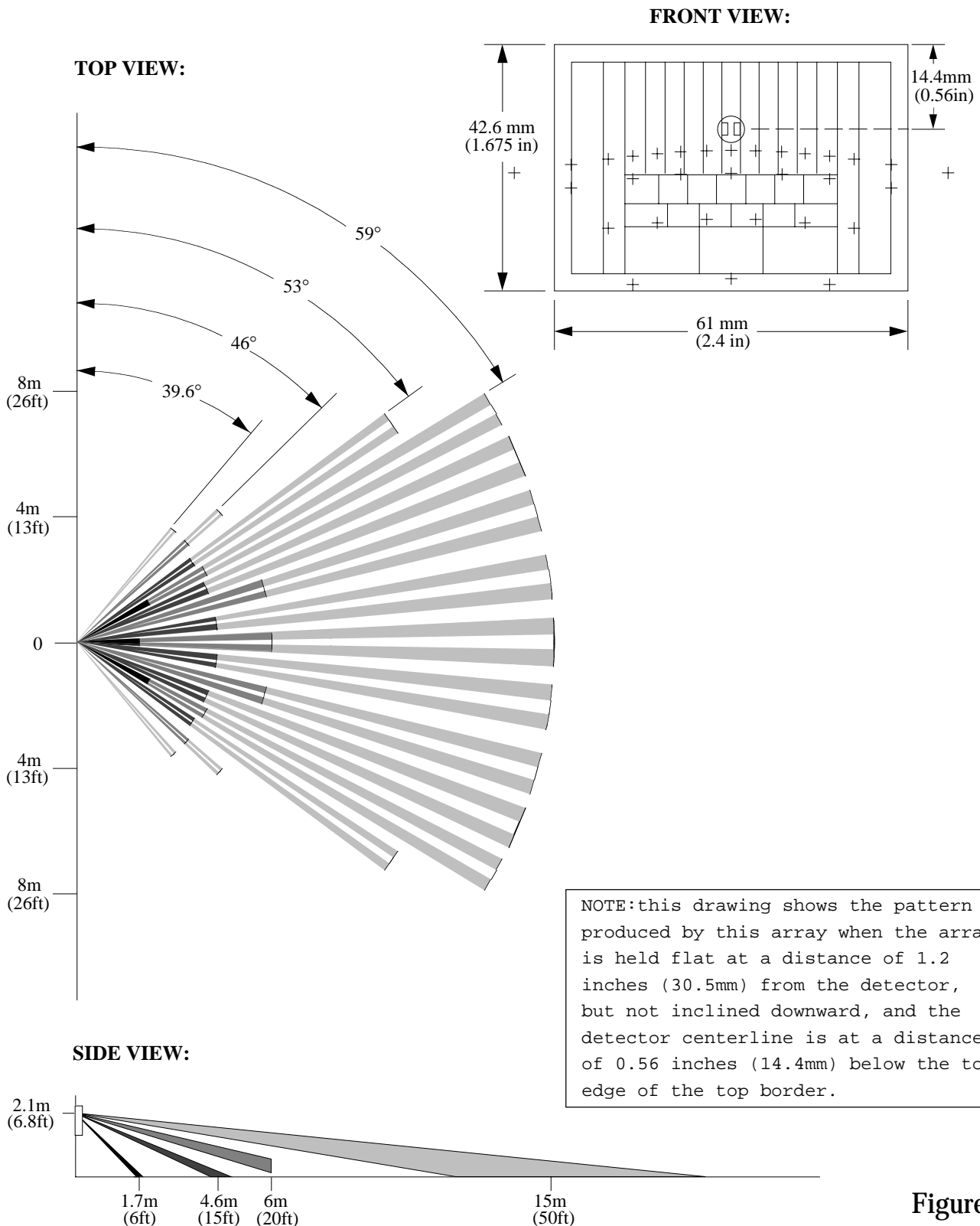

Figure 29

# ANIMAL ALLEY ARRAY

AA 1.2 GI V1

MOUNTED FLAT

## FRONT VIEW:

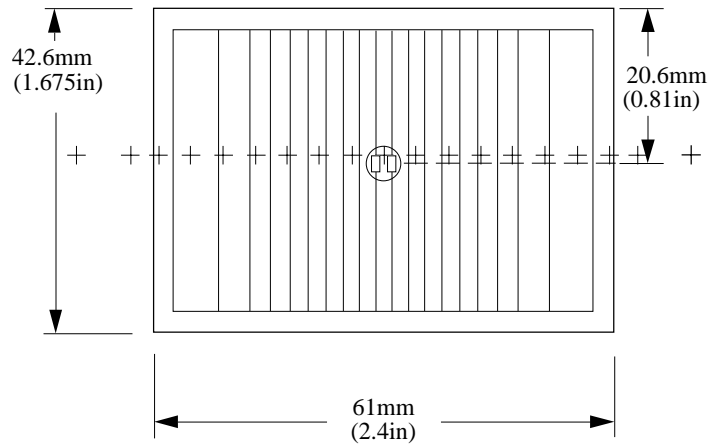

## TOP VIEW:

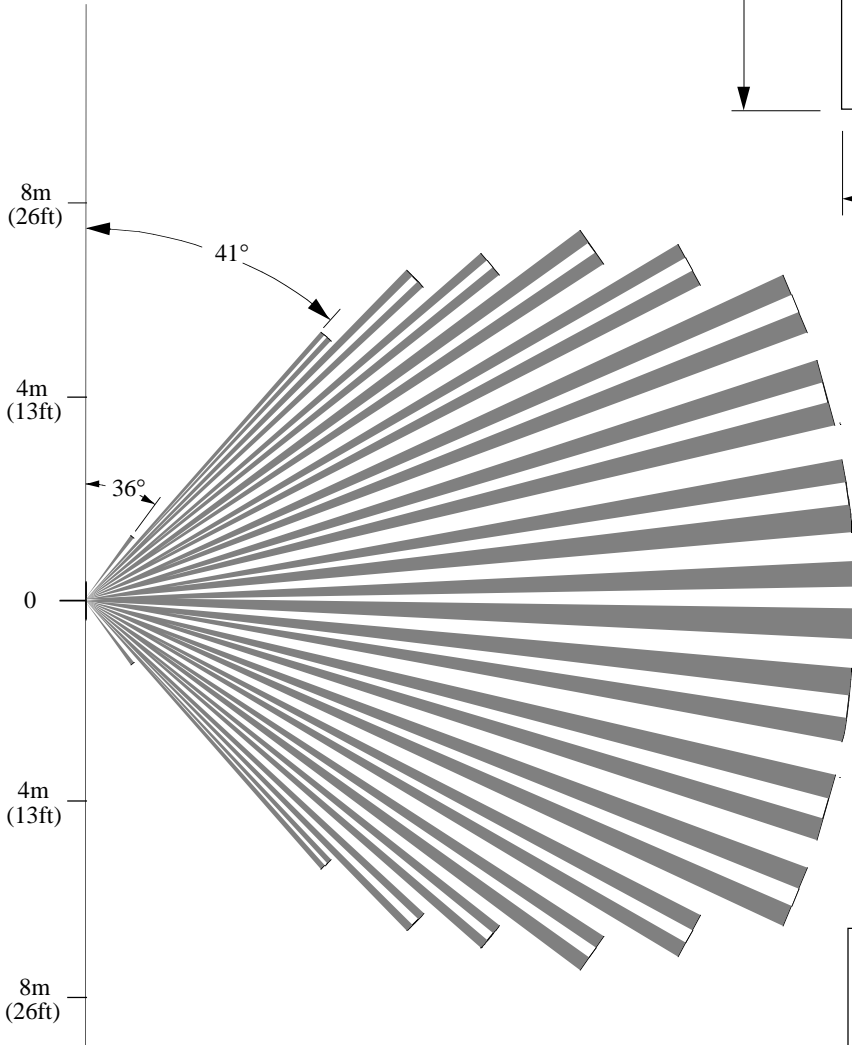

NOTE: this drawing shows the pattern produced by this array when the array is held flat at a distance of 1.2 inches (30.5mm) from the detector, but not inclined downward, and the detector centerline is at a distance of 0.81 inches (20.6mm) below the top edge of the top border.

## SIDE VIEW:

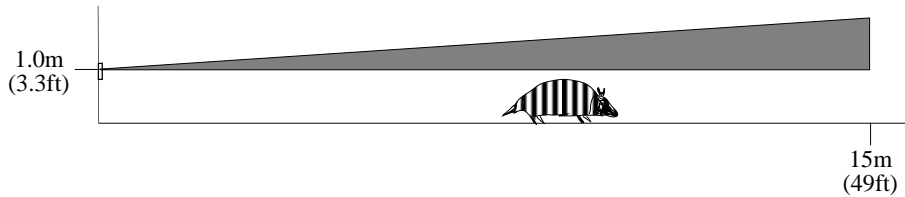

Figure 30